

# State of Nebraska - INVITATION TO BID CONTRACT

Date	11/21/22	Page	1 of 2
Solicitation Number	6736 OF		
Opening Date and Time	12/12/22	2:00 pm	
Buyer	CHRISTIE KELLY (AS)		

**DESTINATION OF GOODS**  
 DEPARTMENT OF TRANSPORTATION  
 5001 S 14TH ST  
 PO BOX 94759  
 LINCOLN NE 68509-4759

Per Nebraska's Transparency in Government Procurement Act, DAS is required to collect statistical information regarding the number of contracts awarded to Nebraska contractors. This information is for statistical purposes only and will not be considered for contract award purposes.

*CDL* NEBRASKA CONTRACTOR AFFIDAVIT: Bidder hereby attests that bidder is a Nebraska Contractor. "Nebraska Contractor" shall mean any bidder who has maintained a bona fide place of business and at least one employee within this state for at least the six (6) months immediately preceding the posting date of this ITB.

\_\_\_\_\_ I hereby certify that I am a Resident disabled veteran or business located in a designated enterprise zone in accordance with Neb. Rev. Stat. §73-107 and wish to have preference, if applicable, considered in the award of this contract.

Contract to supply and deliver 2023 or Current Production Year Ford Transit XLT Side Lift All Wheel Drive (AWD) Transit Vans to the State of Nebraska as per the attached specifications for a one (1) year period from date of award. The contract may be renewed for four (4) additional one (1) year periods when mutually agreeable to the vendor and the State of Nebraska.

(11/21/22 sc)

## INVITATION

Line	Description	Quantity	Unit of Measure	Unit Price	Extended Price
1	2023 OR CURRENT PRODUCTION YEAR FORD TRANSIT XLT SIDE LIFT, ALL WHEEL DRIVE (AWD) TRANSIT VANS WITH DUAL TIRES	50.0000	EA	\$93,948.20	\$4,679,410

*XL vs. XLT (due to OEM availability)*

MAKE: 2023 Ford

MODEL NAME/NUMBER: Transit 350 XL AWD High Roof (U5X)

OPTIONS:

\*\*\*BIDDERS MUST PROVIDE LITERATURE FOR EACH "OPTION" LINE-ITEM BID\*\*\*

### BIDDER MUST COMPLETE THE FOLLOWING

DISCOUNT PAYMENT TERMS: NONE % NET 30 DAYS

By signing this Invitation to Bid form, the bidder guarantees compliance with the provisions stated in this Invitation to Bid, agrees to the terms and conditions unless otherwise agreed to and certifies that bidder maintains a drug free work place environment. Vendor will furnish the items requested within 160 days after receipt of order. Failure to enter Delivery Date may cause quotation to be REJECTED.

Sign Here

*Coy Lightfoot*

(Authorized Signature Mandatory – Form must be signed manually in ink or by DocuSign)

Enter Contact Information Below

VENDOR#

10262067

VENDOR:

Superior Van & Mobility, LLC.

Address:

11147 Mockingbird Dr.  
Omaha, NE 68137

Contact

Coy Lightfoot

Telephone

502-736-7392

Email

clightfoot@superiorvan.com

# State of Nebraska - INVITATION TO BID CONTRACT

Date	11/21/22	Page	2 of 2
Solicitation Number	6736 OF		
Opening Date and Time	12/12/22	2:00 pm	
Buyer	CHRISTIE KELLY (AS)		

**DESTINATION OF GOODS**  
DEPARTMENT OF TRANSPORTATION  
5001 S 14TH ST  
PO BOX 94759  
LINCOLN NE 68509-4759

## INVITATION

Line	Description	Quantity	Unit of Measure	Unit Price	Extended Price
2	REMOVAL OF AMBULATORY PASSENGER SEAT (DEDUCT)	50.0000	EA	<u>-\$900</u>	<u>-\$45,000</u>
3	REAR PASSENGER DUAL INTEGRATED CHILD SEAT, EACH WITH AN INFANT LATCH HOOK, UNDER SEAT RETRACTOR SEAT BELT AND ONE (1) FLIP-UP ARMREST  MAKE: <u>Freedman</u>  MODEL NAME/NUMBER: <u>Caregiver</u>	50.0000	EA	<u>\$1,450</u>	<u>\$72,500</u>
4	REMOVAL OF REAR PASSENGER DUAL INTEGRATED CHILD SEAT (DEDUCT)	50.0000	EA	<u>-\$1,450</u>	<u>-\$72,500</u>
5	REPLACEMENT OF REAR PASSENGER DUAL INTEGRATED CHILD SEAT	50.0000	EA	<u>\$900</u>	<u>\$45,000</u>

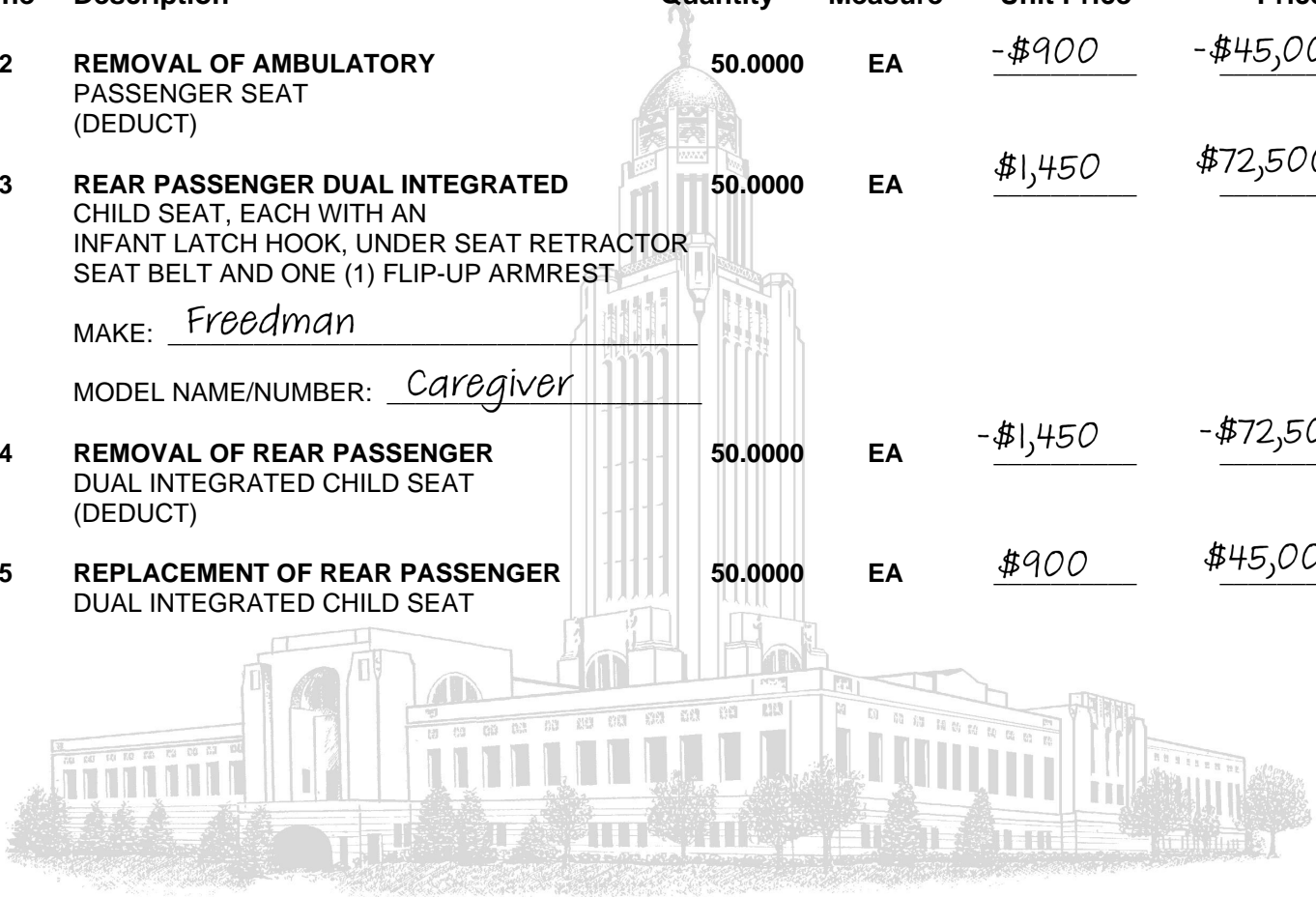

**2023 OR CURRENT PRODUCTION YEAR  
FORD TRANSIT XLT SIDE LIFT ALL WHEEL DRIVE (AWD) TRANSIT VANS  
STATE OF NEBRASKA-NDOT  
INVITATION TO BID  
Number 6736 OF**

The State of Nebraska (State), Department of Administrative Services (DAS), Materiel Division, State Purchasing Bureau (SPB), is issuing this solicitation for a commodity contract, ITB Number 6736 OF for the purpose of selecting a qualified Vendor to provide **2023 or Current Production Year Ford Transit XLT Side Lift All Wheel Drive (AWD) Transit Vans**. A more detailed description can be found in Sections II through VI. The resulting contract may not be an exclusive contract as the State reserves the right to contract for the same or similar goods from other sources now or in the future.

The term of the resulting contract(s) will be one (1) year commencing upon execution of the contract by the State and the Vendor. The Contract includes the option to renew for four (4) additional one (1) year periods upon mutual agreement of the Parties. The State reserves the right to extend the period of this contract beyond the termination date when mutually agreeable to the Parties.

**INFORMATION PERTINENT TO THIS SOLICITATION CAN BE FOUND ON THE INTERNET AT:**

<http://das.nebraska.gov/materiel/purchasing.html>

**IMPORTANT NOTICE:** Pursuant to Neb. Rev. Stat. § 84-602.02, State contracts in effect as of January 1, 2014, and contracts entered into thereafter, must be posted to a public website. The resulting contract, the solicitation, and the successful Vendor's bid or response will be posted to a public website managed by DAS, which can be found at:

<https://statecontracts.nebraska.gov>

In addition, and in furtherance of the State's public records statute (Neb. Rev. Stat. § 84-712 et seq.) all bids, or responses received regarding this solicitation will be posted to the SPB website.

These postings will include the entire bid or response. Vendor must request that proprietary information be excluded from the posting. The Vendor must identify the proprietary information, mark the proprietary information according to state law, and submit the proprietary information in a separate container or envelope marked conspicuously using an indelible method with the words "PROPRIETARY INFORMATION". The Vendor must submit a **detailed written document showing** that the release of the proprietary information would give a business advantage to named business competitor(s) and explain how the named business competitor(s) will gain an actual business advantage by disclosure of information. The mere assertion that information is proprietary or that a speculative business advantage might be gained is not sufficient (See Attorney General Opinion No. 92068, April 27, 1992). **THE VENDOR MAY NOT ASSERT THAT THE ENTIRE BID OR RESPONSE IS PROPRIETARY. COST WILL NOT BE CONSIDERED PROPRIETARY AND IS A PUBLIC RECORD IN THE STATE OF NEBRASKA.** The State will then determine, in its discretion, if the interests served by nondisclosure outweighs any public purpose served by disclosure (See Neb. Rev. Stat. § 84-712.05(3)). The Vendor will be notified of the agency's decision. Absent a State determination that information is proprietary, the State will consider all information a public record subject to release regardless of any assertion that the information is proprietary.

If the agency determines it is required to release proprietary information, the Vendor will be informed. It will be the Vendor's responsibility to defend the Vendor's asserted interest in non-disclosure.

To facilitate such public postings, with the exception of proprietary information, the State of Nebraska reserves a royalty-free, nonexclusive, and irrevocable right to copy, reproduce, publish, post to a website, or otherwise use any contract, bid, or response to this solicitation for any purpose, and to authorize others to use the documents. Any individual or entity awarded a contract, or who submits a bid or response to this solicitation, specifically waives any copyright or other protection the contract, bid, or response to the solicitation may have; and acknowledges that they have the ability and authority to enter into such waiver. This reservation and waiver are a prerequisite for submitting a bid or response to this solicitation, and award of a contract. Failure to agree to the reservation and waiver will result in the bid or response to the solicitation being found non-responsive and rejected.

**Any entity awarded a contract or submitting a bid or response to the solicitation agrees not to sue, file a claim, or make a demand of any kind, and will indemnify and hold harmless the State and its employees, volunteers, agents, and its elected and appointed officials from and against any and all claims, liens, demands, damages, liability, actions, causes of action, losses, judgments, costs, and expenses of every nature, including investigation costs and expenses, settlement costs, and attorney fees and expenses, sustained or asserted against the State, arising out of, resulting from, or attributable to the posting of the contract or the bids and responses to the solicitation, awards, and other documents.**

**INVITATION TO BID  
Number 6736 OF**

**TABLE OF CONTENTS**

<b>TABLE OF CONTENTS.....</b>	<b>ii</b>
<b>GLOSSARY OF TERMS.....</b>	<b>iv</b>
<b>ACRONYM LIST.....</b>	<b>viii</b>
<b>I. PROCUREMENT PROCEDURE.....</b>	<b>1</b>
A. GENERAL INFORMATION.....	1
B. PROCURING OFFICE AND COMMUNICATION WITH STATE STAFF AND EVALUATORS.....	1
C. SCHEDULE OF EVENTS.....	1
D. WRITTEN QUESTIONS AND ANSWERS.....	2
E. SECRETARY OF STATE/TAX COMMISSIONER REGISTRATION REQUIREMENTS (Statutory).....	2
F. ETHICS IN PUBLIC CONTRACTING.....	2
G. DEVIATIONS FROM THE ITB.....	3
H. BID PREPARATION COSTS.....	4
I. FAILURE TO COMPLY WITH ITB.....	4
J. BID CORRECTIONS.....	4
K. LATE BIDS.....	4
L. BID OPENING.....	4
M. ITB REQUIREMENTS.....	4
N. EVALUATION OF BIDS.....	4
O. BEST AND FINAL OFFER.....	5
P. REFERENCE AND CREDIT CHECKS.....	5
Q. AWARD.....	5
R. SPECIFICATIONS.....	6
S. ALTERNATE/EQUIVALENT BIDS.....	6
T. "ALL OR NONE" OR "LUMP SUM" BIDS.....	6
U. EMAIL SUBMISSIONS.....	6
V. BID TABULATIONS.....	6
W. REJECTION OF BIDS.....	6
X. RESIDENT BIDDER.....	6
<b>II. TERMS AND CONDITIONS.....</b>	<b>7</b>
A. GENERAL.....	7
B. NOTIFICATION.....	7
C. PCO REPRESENTATIVE.....	8
D. GOVERNING LAW (Statutory).....	8
E. AMENDMENT.....	8
F. SUBSTITUTIONS.....	8
G. VENDOR PERFORMANCE REPORT(S).....	8
H. NOTICE OF POTENTIAL VENDOR BREACH.....	8
I. BREACH.....	9
J. NON-WAIVER OF BREACH.....	9
K. SEVERABILITY.....	9
L. INDEMNIFICATION.....	9
M. ATTORNEY'S FEES.....	10
N. ASSIGNMENT, SALE, OR MERGER.....	10
O. CONTRACTING WITH OTHER POLITICAL SUB-DIVISIONS OF THE STATE OR ANOTHER STATE.....	10
P. FORCE MAJEURE.....	10
Q. CONFIDENTIALITY.....	11
R. EARLY TERMINATION.....	11
<b>III. CONTRACTOR DUTIES.....</b>	<b>12</b>
A. INDEPENDENT CONTRACTOR / OBLIGATIONS.....	12
B. EMPLOYEE WORK ELIGIBILITY STATUS.....	12
C. COMPLIANCE WITH CIVIL RIGHTS LAWS AND EQUAL OPPORTUNITY EMPLOYMENT / NONDISCRIMINATION (Statutory).....	13
D. COOPERATION WITH OTHER CONTRACTORS.....	13
E. DISCOUNTS.....	13
F. PRICES.....	13
G. COST CLARIFICATION.....	13

**INVITATION TO BID  
Number 6736 OF**

H.	PERMITS, REGULATIONS, LAWS .....	14
I.	NOTICE OF POTENTIAL VENDOR BREACH .....	14
J.	ANTITRUST.....	14
K.	CONFLICT OF INTEREST .....	14
L.	SITE RULES AND REGULATIONS.....	15
M.	ADVERTISING .....	15
N.	NEBRASKA TECHNOLOGY ACCESS STANDARDS (Statutory).....	15
O.	DISASTER RECOVERY/BACK UP PLAN.....	15
P.	DRUG POLICY .....	15
Q.	WARRANTY .....	15
<b>IV.</b>	<b>PAYMENT .....</b>	<b>17</b>
A.	PROHIBITION AGAINST ADVANCE PAYMENT (Statutory).....	17
B.	TAXES (Statutory) .....	17
C.	INVOICES.....	17
D.	INSPECTION AND APPROVAL .....	17
E.	PAYMENT (Statutory).....	17
F.	LATE PAYMENT (Statutory).....	17
G.	SUBJECT TO FUNDING / FUNDING OUT CLAUSE FOR LOSS OF APPROPRIATIONS (Statutory).....	17
H.	RIGHT TO AUDIT (First Paragraph is Statutory) .....	17
<b>V.</b>	<b>SCOPE OF WORK .....</b>	<b>19</b>
A.	SCOPE .....	19
<b>VI.</b>	<b>TECHNICAL SPECIFICATIONS .....</b>	<b>20</b>
A.	VENDOR INSTRUCTIONS.....	20
B.	MANUFACTURER'S MINIMUM SPECIFICATIONS.....	20
C.	NON-COMPLIANCE STATEMENT .....	20
D.	CODE OF FEDERAL REGULATIONS FMVSS .....	20
E.	MOTOR VEHICLE INDUSTRIES REGULATION ACT .....	21
F.	MISCELLANEOUS SPECIFICATIONS.....	21
G.	DIMENSIONS AND CAPACITY.....	21
H.	CHASSIS AND RELATED SYSTEMS .....	22
I.	AUXILIARY SYSTEMS, MISCELLANEOUS PARTS, AND ACCESSORIES .....	23
J.	EMERGENCY EQUIPMENT .....	24
K.	INTERIOR FLOORING & SURFACES .....	24
L.	MODULAR TRACK FLOORING .....	25
M.	EXTERIOR FINISH.....	25
N.	WINDSHIELD AND WINDOWS.....	26
O.	DOORS.....	26
P.	SEATS AND AISLE .....	26
Q.	WHEELCHAIR ACCOMMODATION .....	27
R.	ACCEPTABLE BRANDS .....	29
S.	ANNUAL USAGE, ESTIMATED .....	29
T.	USAGE REPORT .....	30
U.	DELIVERY ARO .....	30
V.	DELIVERY LOCATIONS / INSTRUCTIONS.....	30
W.	ORDERS .....	31
X.	INVOICES.....	31
Y.	QUALITY .....	31
Z.	AUTHORIZED DEALER .....	32
AA.	WARRANTY .....	32

**INVITATION TO BID  
Number 6736 OF**

**GLOSSARY OF TERMS**

**Acceptance Test Procedure:** Benchmarks and other performance criteria, developed by the State or other sources of testing standards, for measuring the effectiveness of products or goods and the means used for testing such performance

**Addendum:** Something to be added or deleted to an existing document; a supplement

**Agency:** Using agencies shall mean and include all officers of the state, departments, bureaus, boards, commissions, councils, and institutions receiving legislative appropriations

**Agent/Representative:** A person authorized to act on behalf of another

**Amend:** To alter or change by adding, subtracting, or substituting

**Amendment:** A written correction or alteration to a document

**Appropriation:** Legislative authorization to expend public funds for a specific purpose. Money set apart for a specific use

**Automated Clearing House:** Electronic network for financial transactions in the United States

**Award:** All purchases, leases, or contracts which are based on competitive bids will be awarded according to the provisions in the solicitation

**Best and Final Offer:** In a competitive bid, the final offer submitted which contains vendor's most favorable terms for price

**Bid:** An offer, bid, or quote submitted by a vendor in a response to a written solicitation

**Bidder:** A vendor who submits an offer bid in response to a written solicitation

**Breach:** Violation of a contractual obligation by failing to perform or repudiation of one's own promise.

**Business:** Any corporation, partnership, individual, sole proprietorship, joint-stock company, joint venture, or any other private legal entity

**Business Day:** Any weekday, except State-recognized holidays

**Calendar Day:** Every day shown on the calendar including Saturdays, Sundays, and State/Federal holidays

**Cancellation:** To call off or revoke a bid, purchase order or contract without expectation of conducting or performing at a later time

**Central Processing Unit:** Any computer or computer system that is used by the State to store, process, or retrieve data or perform other functions using Operating Systems and applications software

**Collusion:** An agreement or cooperation between two or more persons or entities to accomplish a fraudulent, deceitful, or unlawful purpose

**Commodities:** Any equipment, material, supply, or goods; anything movable or tangible that is provided or sold

**Commodities Description:** Detailed descriptions of the items to be purchased; may include information necessary to obtain the desired quality, type, color, size, shape, or special characteristics necessary to perform the work intended to produce the desired results

**Competition:** The effort or action of two (2) or more commercial interests to obtain the same business from third parties

**Confidential Information:** Unless otherwise defined below, "Confidential Information" shall also mean proprietary trade secrets, academic and scientific research work which is in progress and unpublished, and other information which if released would give advantage to business competitors and serve no public purpose (see Neb. Rev. Stat. § 84-712.05(3)). In accordance with Nebraska Attorney General Opinions 92068 and 97033, proof that information is proprietary requires identification of specific, named competitor(s) who would be advantaged by release of the information and the specific advantage the competitor(s) would receive

**Contract:** An agreement between two (2) or more parties creating obligations that are enforceable or otherwise recognizable at law; the writing that sets forth such an agreement

**Contract Administration:** The management of the contract which includes and is not limited to contract signing, contract amendments and any necessary legal actions

## INVITATION TO BID Number 6736 OF

**Contract Management:** The management of day-to-day activities at the agency which includes and is not limited to ensuring deliverables are received, specifications are met, handling meetings, and making payments to the Vendor

**Contract Period:** The duration of the contract

**Contractor:** An individual or entity lawfully conducting business in the State, who seeks or agrees to provide goods or services under the terms of a written contract.

**Cooperative Purchasing:** The combining of requirements of two (2) or more political entities to obtain advantages of volume purchases, reduction in administrative expenses or other public benefits

**Copyright:** A property right in an original work of authorship fixed in any tangible medium of expression, giving the holder the exclusive right to reproduce, adapt and distribute the work

**Crashworthiness:** The body and roof structure of the vehicle shall withstand a static load equal to 150% of the curb weight, evenly distributed on the roof with a maximum of a 6" reduction in any interior dimension.

**Critical Program Error:** Any Program Error, whether or not known to the State, which prohibits or significantly impairs use of the Licensed Software as set forth in the documentation and intended in the contract

**Curb Weight:** The "as delivered" weight of the vehicle with all equipment required for operation, all equipment required by these specifications, and with maximum fuel, oil, and coolant, but without driver or passengers.

**Customer Service:** The process of ensuring customer satisfaction by providing assistance and advice on those products or goods provided by a Vendor

**Default:** The omission or failure to perform a contractual duty

**Deviation:** Any proposed change(s) or alteration(s) to either the Terms and Conditions or deliverables within the scope of the written solicitation or contract

**Disadvantaged Business Enterprise:** A for-profit small business concern (a) that is at least 51% owned by one (1) or more individuals who are both socially and economically disadvantaged or, in the case of a corporation, in which 51% of the stock is owned by one (1) or more such individual(s); and (b) whose management and daily business operations are controlled by one (1) or more of the socially and economically disadvantaged individuals who own it and is certified as such (See 49 Code of Federal Regulations Part 26).

**Evaluation:** The process of examining an offer after opening to determine the vendor's responsibility, responsiveness to requirements, and to ascertain other characteristics of the offer that relate to determination of the successful award

**Extension:** Continuance of a contract for a specified duration upon the agreement of the parties beyond the original Contract Period. Not to be confused with "Renewal Period"

**Free on-Board Destination:** The delivery charges are included in the quoted price and prepaid by the vendor. The vendor is responsible for all claims associated with damages during delivery of product

**Foreign Corporation:** A foreign corporation that was organized and chartered under the laws of another state, government, or country.

**Heavy-Duty:** Exceeding the usual quality or capacity of similar items normally supplied as standard equipment and capable of withstanding unusual stress, temperature, wear, exposure, and/or use.

**Installation Date:** The date when the procedures described in "Installation by Contractor", and "Installation by State", as found in the solicitation, or contract are completed.

**Interested Party:** A person, acting in their personal capacity, or an entity entering into a contract or other agreement creating a legal interest therein

**Invalid Bid:** A bid that does not meet the requirements of the solicitation or cannot be evaluated against the other bids.

**Invitation to Bid:** A written solicitation utilized for obtaining competitive offers for Services or Goods

**Late Bid:** An offer received after the Opening Date and Time

**Licensed Software Documentation:** The user manuals and any other materials in any form or medium customarily provided by the Vendor to the users of the Licensed Software which will provide the State with sufficient information to operate, diagnose, and maintain the Licensed Software properly, safely, and efficiently

**Mandatory:** Required, compulsory, or obligatory

## INVITATION TO BID Number 6736 OF

**May:** Discretionary, permitted; used to express possibility

**Module:** “see System”. A collection of routines and data structures that perform a specific function of software

**Must:** See “Mandatory”.

**National Institute for Governmental Purchasing:** Source used for assignment of universal commodity codes to goods and services

**Open Market Purchase:** Authorization may be given to an agency to purchase items above direct purchase authority due to the unique nature, price, quantity, location of the using agency, or time limitations by the DAS, SPB.

**Opening Date and Time:** Specified date and time for the public opening of received, labeled, and sealed formal bids

**Operating System:** The control program in a computer that provides the interface to the computer hardware and peripheral devices, and the usage and allocation of memory resources, processor resources, input/output resources, and security resources

**Outsourcing:** The contracting out of a business process which an organization may have previously performed internally or has a new need for, to an independent organization from which the process is purchased back

**Payroll & Financial Center:** Electronic procurement system of record

**Platform:** A specific hardware and Operating System combination that is different from other hardware and Operating System combinations to the extent that a different version of the Licensed Software product is required to execute properly in the environment established by such hardware and Operating System combination

**Point of Contact:** The person designated to receive communications and to communicate

**Product:** Something that is distributed commercially for use or consumption and that is usually (1) tangible personal property, (2) the result of fabrication or processing, and (3) an item that has passed through a chain of commercial distribution before ultimate use or consumption

**Program Error:** Code in Licensed Software which produces unintended results or actions, or which produces results or actions other than those described in the specifications. A program error includes, without limitation, any Critical Program Error

**Program Set:** The group of programs and products, including the Licensed Software specified in the solicitation, plus any additional programs and products licensed by the State under the contract for use by the State

**Project:** The total scheme, program, or method worked out for the accomplishment of an objective, including all documentation, commodities, and goods to be provided under the contract

**Proprietary Information:** Proprietary information is defined as trade secrets, academic and scientific research work which is in progress and unpublished, and other information which if released would give advantage to business competitors and service no public purpose (see Neb. Rev. Stat. § 84-712.05(3)). In accordance with Attorney General Opinions 92068 and 97033, proof that information is proprietary requires identification of specific named competitor(s) advantaged by release of the information and the demonstrated advantage the named competitor(s) would gain by the release of information

**Protest/Grievance:** A complaint about a governmental action or decision related to the solicitation or resultant contract, brought by a vendor who has timely submitted a bid in connection with the award in question, to AS Materiel Division or another designated agency with the intention of achieving a remedial result

**Public Bid Opening:** The process of opening correctly submitted offers at the time and place specified in the written solicitation and in the presence of anyone who wished to attend

**Quote:** See “Bid”.

**Recommended Hardware Configuration:** The data processing hardware (including all terminals, auxiliary storage, communication, and other peripheral devices) to the extent utilized by the State as recommended by the Vendor.

**Release Date:** The date of public release of the written solicitation to seek offers

**Renewal Period:** Optional contract periods subsequent to the original Contract Period for a specified duration with previously agreed to Terms and Conditions. Not to be confused with Extension.

**Request for Information:** A general invitation to vendor is requesting information for a potential future solicitation. The RFI is typically used as a research and information gathering tool for preparation of a solicitation



## INVITATION TO BID Number 6736 OF

**Resident Disabled Veteran:** Any person (a) who resides in the State of Nebraska, who served in the United States Armed Forces, including any reserve component or the National Guard, who was discharged or otherwise separated with a characterization of honorable or general (under honorable conditions), and who possesses a disability rating letter issued by the United States Department of Veterans Affairs establishing a service-connected disability or a disability determination from the United States Department of Defense and (b)(i) who owns and controls a business or, in the case of a publicly owned business, more than fifty percent of the stock is owned by one or more persons described in subdivision (a) of this subsection and (ii) the management and daily business operations of the business are controlled by one or more persons described in subdivision(a) of this subsection. Any contract entered into without compliance with this section shall be null and void.

**Responsible Vendor:** A Vendor who has the capability in all respects to perform fully and lawfully all requirements with integrity and reliability to assure good faith performance

**Responsive Vendor:** A Vendor who has submitted a bid which conforms to all requirements of the solicitation document

**Riser:** A stair riser is the near-vertical element in a set of stairs, forming the space between one step and the next. It is sometimes slightly inclined from the vertical so that its top is closer than its base to the person climbing the stairs.

**Shall:** See "Mandatory".

**Should:** Expected; suggested, but not necessarily mandatory

**Software License:** Legal instrument with or without printed material that governs the use or redistribution of licensed software

**Specifications:** The detailed statement, especially of the measurements, quality, materials, and functional characteristics, or other items to be provided under a contract

**Statutory:** These clauses are controlled by state law and are not subject to negotiation

**Subcontractor:** Individual or entity with whom the contractor enters a contract to perform a portion of the work awarded to the contractor

**Stair Riser:** See "Riser".

**System (see Module):** Any collection or aggregation of two (2) or more Modules that is designed to function, or is represented by the Vendor as functioning or being capable of functioning, as an entity

**Termination:** Occurs when the contract expires or either party, pursuant to a power created by agreement or law puts an end to the contract prior to the stated expiration date. All obligations which are still executory on both sides are discharged but any right based on prior breach or performance survives

**Third-Party:** Any person or entity, including but not limited to fiduciaries, shareholders, owners, officers, managers, employees, legally disinterested persons, and sub-contractors or agents, and their employees. It shall not include any entity or person who is an interested Party to the contract or agreement

**Trade Secret:** Information, including, but not limited to, a drawing, formula, pattern, compilation, program, device, method, technique, code, or process that (a) derives independent economic value, actual or potential, from not being known to, and not being ascertainable by proper means by, other persons who can obtain economic value from its disclosure or use; and (b) is the subject of efforts that are reasonable under the circumstances to maintain its secrecy (see Neb. Rev. Stat. § 87-502(4))

**Trademark:** A word, phrase, logo, or other graphic symbol used by a manufacturer or vendor to distinguish its product from those of others, registered with the U.S. Patent and Trademark Office

**Upgrade:** Any change that improves or alters the basic function of a product of service

**Vendor Performance Report:** A report completed by the using agency and submitted to SPB documenting products or services delivered or performed which exceed or fail to meet the terms of the purchase order, contract, and/or solicitation specifications.

**Vendor:** Inclusive term for any Bidder or Contractor.

**Will:** See "Mandatory".

**INVITATION TO BID  
Number 6736 OF**

**ACRONYM LIST**

**ACH:** Automated Clearing House  
**ADA:** Americans with Disabilities Act  
**ARO:** After Receipt of Order  
**AWD:** All Wheel Drive  
**BAFO:** Best and Final Offer  
**BTU:** British Thermal Unit  
**CFR:** Code of Federal Regulations  
**CPR:** Cardiopulmonary Resuscitation  
**CPU:** Central Processing Unit  
**CRS:** Child Restraint System  
**DAS:** Department of Administrative Services  
**DBE:** Disadvantaged Business Enterprise  
**DOT:** United States Department of Transportation  
**F:** Fahrenheit  
**FMVSS:** Federal Motor Vehicle Safety Standards  
**FOB:** Free on Board  
**GSA:** General Services Administration  
**GWVR:** Gross Vehicle Weight Rating  
**I.D.:** Identification  
**ISO:** International Organization for Standardization  
**ITB:** Invitation to Bid  
**lb.:** Pound  
**L:** Liter  
**mm:** Millimeter  
**NHTSA:** National Highway Traffic Safety Administration  
**NIGP:** National Institute for Governmental Purchasing  
**NDOT:** Nebraska Department of Transportation  
**OEM:** Original Equipment Manufacturer  
**PFC:** Payroll & Financial Center  
**PCO:** Procurement Contracts Officer  
**POC:** Point of Contact  
**PSI:** Pound per square inch

**INVITATION TO BID  
Number 6736 OF**

**RFI:** Request for Information

**RPM:** Revolutions per Minute

**SPB:** State Purchasing Bureau

**UL:** Underwriter Laboratories

**USC:** United States Code

**V:** Volt

**INVITATION TO BID  
Number 6736 OF**

**I. PROCUREMENT PROCEDURE**

**A. GENERAL INFORMATION**

The solicitation is designed to solicit bids from qualified Vendors who will be responsible for providing **2023 or Current Production Year Ford Transit XLT Side Lift All Wheel Drive (AWD) Transit Vans** at a competitive and reasonable cost. Terms and Conditions, Project Description and Scope of Work, Bid instructions, and Cost Bid Requirements may be found in Sections II through VI.

Bids shall conform to all instructions, conditions, and requirements included in the solicitation. Prospective Vendors are expected to carefully examine all documents, schedules, and requirements in this solicitation, and respond to each requirement in the format prescribed. Bids may be found non-responsive if they do not conform to the solicitation.

**B. PROCURING OFFICE AND COMMUNICATION WITH STATE STAFF AND EVALUATORS**

Procurement responsibilities related to this solicitation reside with SPB. The POC for the procurement is as follows:

**ITB:** 6736 OF  
**Name:** Christie Kelly, PCO  
Rob Taylor, PCO  
**Agency:** State Purchasing Bureau  
**Address:** 1526 K Street, Suite 130  
Lincoln, NE 68508

**Telephone:** 402-471-6500

**E-Mail:** [as.materielpurchasing@nebraska.gov](mailto:as.materielpurchasing@nebraska.gov)

From the date the solicitation is issued until the Intent to Award is issued, communication from the Vendor is limited to the POC listed above. After the Intent to Award is issued, the Vendor may communicate with individuals the State has designated as responsible for negotiating the contract on behalf of the State. No member of the State Government or employee of the State is empowered to make binding statements regarding this solicitation. The POC will issue any answers, clarifications, or amendments regarding this solicitation in writing. Only the SPB or awarding agency can award a contract. Vendors shall not have any communication with or attempt to communicate or influence any evaluator involved in this solicitation.

The following exceptions to these restrictions are permitted:

1. Contact made pursuant to pre-existing contracts or obligations;
2. Contact required by the schedule of events, or an event scheduled later by POC; and,
3. Contact required for negotiation and execution of the final contract.

*The State reserves the right to reject a vendor's bid, withdraw an Intent to Award, or terminate a contract if the State determines there has been a violation of these procurement procedures.*

**C. SCHEDULE OF EVENTS**

The State expects to adhere to the tentative procurement schedule shown below. It should be noted; however, dates are approximate and subject to change.

	<b>ACTIVITY</b>	<b>DATE/TIME</b>
1	Release ITB	November 21, 2022
2	Last Day to Submit Written Questions <b>Upload electronic Question submissions for 6736 OF via ShareFile to:</b>  <a href="https://nebraska.sharefile.com/r-r127a26ed662440ee9facec2e361d8017">https://nebraska.sharefile.com/r-r127a26ed662440ee9facec2e361d8017</a>	November 28, 2022
3	State Responds to Written Questions through an Addendum to be posted to the internet at:  <a href="https://das.nebraska.gov/materiel/bidopps.html#">https://das.nebraska.gov/materiel/bidopps.html#</a>	December 5, 2022

**INVITATION TO BID  
Number 6736 OF**

ACTIVITY	DATE/TIME
<p>4 Electronic Bid Opening via Zoom Meeting: Bids are to be Electronically submitted via ShareFile link below:</p> <p><b>Upload electronic Bid submissions for 6736 OF via ShareFile to:</b></p> <p><a href="https://nebraska.sharefile.com/r-rea3b39d79b5448bc9c9f8e661a6419dc">https://nebraska.sharefile.com/r-rea3b39d79b5448bc9c9f8e661a6419dc</a></p> <p><b>Zoom Meeting Information:</b></p> <p><a href="https://us02web.zoom.us/j/7318536781?pwd=cHRFNjZzRzBwSitiVDZSQytEa2Zwdz09">https://us02web.zoom.us/j/7318536781?pwd=cHRFNjZzRzBwSitiVDZSQytEa2Zwdz09</a></p> <p><b>Meeting ID: 731 853 6781</b></p> <p><b>Passcode: 4Gkv2t</b></p> <p><b>IT IS THE BIDDERS' RESPONSIBILITY TO ENSURE ALL BIDS SHALL BE SUBMITTED AND RECEIVED BY THE DATE AND TIME INDICATED IN THE SCHEDULE OF EVENTS FOR EACH BID SUBMITTED.</b></p>	<p>December 12, 2022 2:00 p.m. Central Time</p>

**D. WRITTEN QUESTIONS AND ANSWERS**

Questions regarding the meaning or interpretation of any ITB provision should be submitted electronically or in writing to SPB and clearly titled "ITB Number 6736 OF 2023 or Current Production Year Ford Transit XLT Side Lift All Wheel Drive (AWD) Transit Vans Questions". The POC is not obligated to respond to questions are received late per the Schedule of Events.

Bidders should present, as questions, any assumptions upon which the Bidder's bid is, or might be, developed. Bids will be evaluated without consideration of any known or unknown assumptions of a Bidder. The contract will not incorporate any known or unknown assumptions of a Bidder.

Questions should be uploaded using the following ShareFile link: <https://nebraska.sharefile.com/r-r127a26ed662440ee9facec2e361d8017> but may also be emailed.

It is recommended the Bidder submit questions using the following format:

ITB Section Reference	ITB Page Number	Question

Answers will be provided through an Addendum to be posted on the internet at <https://das.nebraska.gov/materiel/bidopps.html#> as shown in the "Schedule of Events".

**E. SECRETARY OF STATE/TAX COMMISSIONER REGISTRATION REQUIREMENTS (Statutory)**

All Vendors must be authorized to transact business in the State and comply with all Nebraska Secretary of State Registration requirements. The Vendor who is the recipient of an Intent to Award will be required to certify that it has complied and produce a true and correct copy of its current (within ninety (90) calendar days of the intent to award) Certificate or Letter of Good Standing, or in the case of a sole proprietorship, provide written documentation of sole proprietorship and the United States Citizenship Attestation Form, available on the DAS website at: <https://sos.nebraska.gov/business-services/explanation-us-citizen-attestation-form>. This must be accomplished prior to execution of the contract.

**F. ETHICS IN PUBLIC CONTRACTING**

The State reserves the right to reject proposals, withdraw an intent to award or award, or terminate a contract if a Vendor commits or has committed ethical violations, which include, but are not limited to:

- Offering or giving, directly or indirectly, a bribe, fee, commission, compensation, gift, gratuity, or anything of value to any person or entity in an attempt to influence the bidding process;
- Utilize the services of lobbyists, attorneys, political activists, or consultants to influence or subvert the bidding process;
- Being considered for, presently being, or becoming debarred, suspended, ineligible, or excluded from contracting with any state or federal entity;
- Submitting a bid on behalf of another party or entity;

**INVITATION TO BID  
Number 6736 OF**

5. Collude with any person or entity to influence the bidding process, submit sham bids, preclude bidding, fix pricing or costs, create an unfair advantage, subvert the bid, or prejudice the State.

The Vendor shall include this clause in any subcontract entered into for the exclusive purpose of performing this contract.

Vendor shall have an affirmative duty to report any violations of this clause by the Vendor throughout the bidding process, and throughout the term of this contract for the successful Vendor and their subcontractors.

**G. DEVIATIONS FROM THE ITB**

The requirements contained in the solicitation (Sections II through VI) become a part of the Terms and Conditions of the contract resulting from this solicitation. Any deviations from the solicitation in Sections II through VI must be clearly defined by the Contractor in its proposal and, if accepted by the State, will become part of the contract. Any specifically defined deviations must not be in conflict with the basic nature of the solicitation, solicitation requirements, or applicable state or federal laws or statutes. "Deviation", for the purposes of this solicitation, means any proposed changes or alterations to either the contractual language or deliverables within the scope of this solicitation. The State discourages deviations and reserves the right to reject proposed deviations.

**A. ELECTRONIC SUBMISSION OF BIDS**

All bids must be submitted to SPB in the matter set forth below and be manually signed in an indelible manner, or by DocuSign, It is the Bidder's responsibility to submit the Electronic Bid(s) along with any other required documents as stated in the ITB and be received by the date and time of the Bid Opening indicated in the Schedule of Events. **The State is not responsible for bids that are late or lost, regardless of cause (e.g., hardware, software, or electronic failure) or fault. Late bids will not be accepted.**

It is the responsibility of the Bidder to check the website often at <https://das.nebraska.gov/materiel/bidopps.html> for all information relevant to this ITB to include Addenda issued prior to the Opening Date and Time.

SPB will **ONLY** accept bids by mail, email, voice, or telephone for one-time purchases under \$50,000.00.

**1. ELECTRONICALLY UPLOADING BID(S) TO SHAREFILE (SUBMITTED DOCUMENTS MUST NOT BE PASSWORD PROTECTED):**

- a. Bidders should upload bid(s) via ShareFile to <https://nebraska.sharefile.com/r-rea3b39d79b5448bc9c9f8e661a6419dc>
- b. Each bid will have an individual ITB ShareFile link. **Bidders are to be sure to upload their Bid(s) to the correct ShareFile link listed in the bid.**
- c. Not all browsers are compatible with ShareFile. **Currently Chrome, Internet Explorer and Firefox are compatible, but Microsoft Edge is not.**
- d. **After the bidder clicks the bid submission link, the bidder will be prompted to enter contact information including an e-mail address so that the bidder will receive a confirmation email confirming the successful upload directly from ShareFile.**
- e. If it is the bidder's intent to submit multiple bids, the bidder must clearly identify each submission separately (see "Electronic ITB File Names" below).
- f. The Bidder is solely responsible for any variance between the copies submitted.
- g. If multiple bids are submitted, the State will retain only the most recently submitted bid.
- h. **Any Proprietary information (if applicable) should be uploaded as separate and distinct files.**
- i. **Do not submit bid file(s) more than 30 days prior to the Bid Opening. Once uploaded the bid documents are only available for 30 days.**

**2. ELECTRONIC ITB FILE NAMES**

- a. The Bidder should clearly identify the uploaded Bid files.
- b. **DO NOT ADD any language to the naming conventions below.** Long titles can make the files difficult to work with. Consistency is key.
- c. If the bidder submits the bid/bid documents as **one (1) complete packet (preferred method excluding Proprietary documentation)**, please use the following naming convention:

# INVITATION TO BID

## Number 6736 OF

- **6736 OF 2023 Ford Transit XLT Side Lift AWDNAME OF BIDDER** Bid.

- d. If the bidder submits the bid/bid documents as separate files, please use the following naming convention(s):
- **6736 OF 2023 Ford Transit XLT Side Lift AWD NAME OF BIDDER** Bid.
  - **6736 OF 2023 Ford Transit XLT Side Lift AWD NAME OF BIDDER** File 1, File 2, File 3, etc.
- e. If multiple bids are submitted for the same ITB number and Attachment, follow the same naming convention as letter “e”, for example:
- **6736 OF 2023 Ford Transit XLT Side Lift AWD NAME OF BIDDER** Bid 2
  - **6736 OF 2023 Ford Transit XLT Side Lift AWD NAME OF BIDDER** Bid 2 File 1, Bid 2 File 2, Bid 2 File 3, etc.

### H. BID PREPARATION COSTS

The State shall not incur any liability for any costs incurred by Vendor in replying to this solicitation, including any activity related to bidding on this solicitation.

### I. FAILURE TO COMPLY WITH ITB

Violation of the Terms and Conditions contained in this solicitation or any resultant contract, at any time before or after the award, shall be grounds for action by the State which may include, but is not limited to, the following:

1. Rejection of a Vendor's bid;
2. Withdrawal of the Intent to Award;
3. Withdrawal of the Award;
4. Negative Vendor Performance Report(s)
5. Termination of the resulting contract;
6. Legal action; or,
7. Suspension of the Vendor from further bidding with the State for the period of time relative to the seriousness of the violation, such period to be within the sole discretion of the State.

### J. BID CORRECTIONS

A Vendor may correct a mistake in a bid prior to the time of opening by giving written notice to the State of intent to withdraw the proposal for modification or to withdraw the proposal completely. Changing a bid after opening may be permitted if the change is made to correct a minor error that does not affect price, quantity, quality, delivery, or contractual conditions. In case of a mathematical error in extension of price, unit price shall govern.

### K. LATE BIDS

Bids received after the time and date of the bid opening will be considered late bids. Late bids will be returned unopened, if requested by the Vendor and at Vendor's expense. The State is not responsible for bids that are late or lost regardless of cause or fault.

### L. BID OPENING

Anyone may attend the opening. It is considered a public opening. The Procurement Contracts Officer will read the names of the respondents. Depending upon the complexity of the bid for goods, the Procurement Contracts Officer may read the bids aloud or allow bids to be available for viewing by the public during the bid opening. Once the bid opening has concluded, the bids will not be available for viewing until the Intent to Award has been posted. An initial bid tabulation will be posted to the website as soon as feasible. Information identified as proprietary by the submitting Vendor, in accordance with the solicitation and state statute, will not be posted. If the state determines submitted information should not be withheld, in accordance with the [Public Records Act](#), or if ordered to release any withheld information, said information may then be released. The submitting Vendor will be notified of the release and it shall be the obligation of the submitting Vendor to take further action if it believes the information should not be released.

### M. ITB REQUIREMENTS

The bids will first be examined to determine if all requirements listed below have been addressed and whether further evaluation is warranted. Bids not meeting the requirements may be rejected as non-responsive. The requirements are:

1. Original Commodity ITB form signed using an indelible method (electronic signatures are acceptable);
2. Clarity and responsiveness of the bid;
3. Completed Sections II through VI; and,
4. Completed ITB Form or State's Bid Sheet.

### N. EVALUATION OF BIDS

**Neb. Rev. Stat. § 81-161 allows the quality of performance of previous contracts to be considered when evaluating responses to competitively bid solicitations in determining the lowest responsible bidder.** Information obtained from any Vendor Performance Report may be used in evaluating responses to solicitations for goods and services to determine the best value for the State.

## INVITATION TO BID Number 6736 OF

**Neb. Rev. Stat. § 73-107 allows for a preference for a resident disabled veteran or business located in a designated enterprise zone.** When a state contract is to be awarded to the lowest responsible bidder, a resident disabled veteran or a business located in a designated enterprise zone under the Enterprise Zone Act shall be allowed a preference over any other resident or nonresident bidder, if all other factors are equal.

Therefore, a resident disabled veteran or business located in a designated enterprise zone who wishes to be allowed preference must submit a bid in accordance with **Neb. Rev. Stat. § 73-107** and must so indicate on the ITB cover page by placing a mark in the space before the statement "I hereby certify that I am a Resident disabled veteran or business located in a designated enterprise zone in accordance with Neb. Rev. Stat. § 73-107 and wish to have preference, if applicable, considered in the award of this contract." and must submit the following documentation within ten (10) business days of request:

1. Documentation from the United States Armed Forces confirming service;
2. Documentation of discharge or otherwise separated with a characterization of honorable or general (under honorable conditions);
3. Disability rating letter issued by the United States Department of Veterans Affairs establishing a service-connected disability or a disability determination from the United States Department of Defense; and
4. Documentation which shows ownership and control of a business or, in the case of a publicly owned business, more than fifty percent of the stock is owned by one (1) or more persons described in subdivision (a) of this subsection; and the management and daily business operations of the business are controlled by one (1) or more persons described in subdivision (a) of this subsection.

Failure to submit the requested documentation within ten (10) business days of notice will disqualify the vendor from consideration of the preference.

**O. BEST AND FINAL OFFER**

If BAFOs are requested by the State and submitted by the vendor, they will be evaluated (using the stated BAFO criteria) and ranked by the Evaluation Committee. The State reserves the right to conduct more than one BAFO. The award will then be granted to the lowest responsible vendor. However, a vendor should provide its best offer in its original bid. Vendors should not expect that the State will request a BAFO.

**P. REFERENCE AND CREDIT CHECKS**

The State reserves the right to conduct and consider reference and credit checks. The State reserves the right to use third parties to conduct reference and credit checks. By submitting a bid in response to this solicitation, the vendor grants to the State the right to contact or arrange a visit in person with any or all of the vendor's clients. Reference and credit checks may be grounds to reject a bid, withdraw an intent to award, or rescind the award of a contract.

**Q. AWARD**

The State reserves the right to evaluate bids and award contracts in a manner utilizing criteria selected at the State's discretion and in the State's best interest. After evaluation of the bids, or at any point in the solicitation process, the State of Nebraska may take one or more of the following actions:

1. Amend the solicitation;
2. Extend the time of or establish a new bid opening time;
3. Waive deviations or errors in the State's solicitation process and in vendor bids that are not material, do not compromise the solicitation process or a vendor's bid, and do not improve a vendor's competitive position;
4. Accept or reject a portion of or all of a bid;
5. Accept or reject all bids;
6. Withdraw the solicitation;
7. Elect to rebid the solicitation;
8. Award single lines or multiple lines to one or more vendors; or,
9. Award one or more all-inclusive contracts.

The State of Nebraska may consider, but is not limited to considering, one or more of the following award criteria:

1. Price;
2. Location;
3. Quality;
4. Delivery time;
5. Vendor qualifications and capabilities; and,
6. State contract management requirements and/or costs.

The solicitation does not commit the State to award a contract. Once Intent to Award decision has been determined, it will be posted to the Internet at:

<https://das.nebraska.gov/materiel/bidopps.html>



## INVITATION TO BID Number 6736 OF

Any protests must be filed by a vendor within ten (10) business days after the Intent to Award decision is posted to the Internet. The Protest/Grievance Procedure document is available on the Internet at:

[https://das.nebraska.gov/materiel/docs/pdf/ProtestGrievanceWithGuidance\\_08042021.pdf](https://das.nebraska.gov/materiel/docs/pdf/ProtestGrievanceWithGuidance_08042021.pdf)

### R. SPECIFICATIONS

Any manufacturer's names, trade names, brand names, information and/or catalog numbers listed in a specification are for reference and not intended to limit competition but will be used as the standard by which equivalent material offered will be judged. The Materiel Administrator or their designee will be the sole judge of equivalency. The Vendor may offer any brands which meets or exceeds the specification. When a specific product is required, the solicitation will so state. Any item bid is to be the latest current model under standard production at the time of order. No used or refurbished equipment will be accepted, unless otherwise stated.

### S. ALTERNATE/EQUIVALENT BIDS

The Vendor may offer bids which vary from the express specifications of the solicitation. The State reserves the right to consider and accept such bids if, in the judgment of the Materiel Administrator or their designee, the bid will result in goods and/or services equivalent to or better than those which would be supplied in the original bid specifications. The Vendor must indicate on the solicitation the manufacturer's name, number and shall submit with their bid, sketches, descriptive literature and/or complete specifications. **Reference to literature submitted with a previous bid will not satisfy this provision.** Bids which do not comply with these requirements are subject to rejection. In the absence of any stated deviation or exception, the bid will be accepted as in strict compliance with all terms, conditions and specifications, and the Vendor shall be held liable, therefore.

### T. "ALL OR NONE" OR "LUMP SUM" BIDS

The State reserves the right to award contracts "item-by-item", by groups or as a total when in the best interest of the State. In addition to the aforementioned types of awards, Vendors may submit additional bid(s) on an "all or none" or "lump sum" basis. An "all or none" bid is a conditional bid which requires the award of all items on which bids are offered and the Vendor declines to accept an "item-by-item", group or total bid. A "lump sum" bid is one in which the Vendor offers a lower price than the sum of the "item-by-item" or total bids if all items' bids are awarded but agrees to deliver individual items at the prices quoted.

**If submitting an "all or none" bid or a "lump sum" bid, please indicate such on the ITB form and Bid Documents.**

### U. EMAIL SUBMISSIONS

SPB will not accept bids by email, voice, or telephone bids **except** for one-time purchases under \$50,000.00.

### V. BID TABULATIONS

Bid tabulations are available on the website at: <https://das.nebraska.gov/materiel/bidopps.html>.

### W. REJECTION OF BIDS

The State reserves the right to reject any or all bids, wholly or in part, in the best interest of the State.

### X. RESIDENT BIDDER

Pursuant to Neb. Rev. Stat. §§ 73-101.01 through 73-101.02, a Resident Bidder shall be allowed a preference against a Non-resident Bidder from a state which gives or requires a preference to Bidders from that state. The preference shall be equal to the preference given or required by the state of the Nonresident Bidders. Where the lowest responsible bid from a resident Bidder is equal in all respects to one from a nonresident Bidder from a state which has no preference law, the resident Bidder shall be awarded the contract. The provision of this preference shall not apply to any contract for any project upon which federal funds would be withheld because of the provisions of this preference.

**INVITATION TO BID  
Number 6736 OF**

**II. TERMS AND CONDITIONS**

**Vendors should complete Section II through VI as part of their bid.** Vendor is expected to read the Terms and Conditions and must initial either accept, reject, or reject and provide alternative language for each clause. The Vendor should also provide an explanation of why the Vendor rejected the clause or rejected the clause and provided alternate language using "Track Changes". Upon request an electronic copy of the bid with "Track Changes" must be submitted in an editable Word format. By signing the solicitation, Vendor is agreeing to be legally bound by all the accepted Terms and Conditions, and any proposed alternative Terms and Conditions submitted with the bid. The State reserves the right to negotiate rejected or proposed alternative language. If the State and Vendor fail to agree on the final Terms and Conditions, the State reserves the right to reject the bid. The State is soliciting bids in response to the solicitation. The State reserves the right to reject bids that attempt to substitute the Vendor's commercial contracts and/or documents for this solicitation.

The Vendor should submit with their bid any license, user agreement, service level agreement, or similar documents that the Vendor wants incorporated in the Contract. Upon notice of Intent to Award, the Vendor must submit a copy of these documents in an editable Word format. The State will not consider incorporation of any document not submitted with the Vendor's bid. These documents shall be subject to negotiation and will be incorporated as addendums if agreed to by the Parties.

If a conflict or ambiguity arises after the addendums have been negotiated and agreed to, the addendums shall be interpreted as follows:

1. If only one (1) Party's document has a particular clause, then that clause shall control;
2. If both Party's documents have a similar clause, but the clauses do not conflict, the clauses shall be read together; and,
3. If both Party's documents have a similar clause, but the clauses conflict, the State's clause shall control.

**A. GENERAL**

Accept (Initial)	Reject (Initial)	Reject & Provide Alternative Response (Initial)	NOTES/COMMENTS:
CDL			

The contract resulting from this solicitation shall incorporate the following documents:

1. Invitation to Bid and Addenda;
2. Amendments to the solicitation;
3. Questions and Answers;
4. Vendor's bid;
5. The executed Contract and any Addenda, if applicable, and properly submitted documents; and,
6. Amendments to the Contract

These documents constitute the entirety of the contract.

Unless otherwise specifically stated in a future contract amendment, in case of any conflict between the incorporated documents, the documents shall govern in the following order of preference with number one (1) receiving preference over all other documents and with each lower numbered document having preference over any higher numbered document: 1) Amendment to the executed Contract with the most recent dated amendment having the highest priority, 2) executed Contract and any attached Addenda, 3) Amendments to solicitation and any Questions and Answers, 4) the original solicitation document and any Addenda, and 5) the Vendor's submitted Bid.

Any ambiguity or conflict in the contract discovered after its execution, not otherwise addressed herein, shall be resolved in accordance with the rules of contract interpretation as established in the State.

**B. NOTIFICATION**

Accept (Initial)	Reject (Initial)	Reject & Provide Alternative Response (Initial)	NOTES/COMMENTS:
CDL			

The Vendor and the State shall identify a contract manager who shall serve as the POC for the executed contract. Communications regarding the executed contract shall be in writing and shall be deemed to have been given if delivered via email, personally, or by U.S. Mail. Either party may change its address for notification purposes by giving notice of the change and setting forth the new address and an effective date.

**INVITATION TO BID  
Number 6736 OF**

**C. PCO REPRESENTATIVE**

The State reserves the right to appoint a PCO Representative to manage or assist the PCO in managing the contract on behalf of the State. The PCO Representative will be appointed in writing, and the appointment document will specify the extent of the PCO Representative authority and responsibilities. If a PCO Representative is appointed, the Vendor will be provided a copy of the appointment document and is expected to cooperate accordingly with the PCO Representative. The PCO Representative has no authority to bind the State to a contract, amendment, addendum, or other change or addition to the contract.

**D. GOVERNING LAW (Statutory)**

Notwithstanding any other provision of this contract, or any amendment or addendum(s) entered into contemporaneously or at a later time, the parties understand and agree that, (1) the State of Nebraska is a sovereign state and its authority to contract is therefore subject to limitation by the State's Constitution, statutes, common law, and regulation; (2) this contract will be interpreted and enforced under the laws of the State of Nebraska; (3) any action to enforce the provisions of this contract must be brought in the State of Nebraska per state law; (4) the person signing this contract on behalf of the State of Nebraska does not have the authority to waive the State's sovereign immunity, statutes, common law, or regulations; (5) the indemnity, limitation of liability, remedy, and other similar provisions of the final contract, if any, are entered into subject to the State's Constitution, statutes, common law, regulations, and sovereign immunity; and, (6) all Terms and Conditions of the final contract, including but not limited to the clauses concerning third-party use, licenses, warranties, limitations of liability, governing law and venue, usage verification, indemnity, liability, remedy or other similar provisions of the final contract are entered into specifically subject to the State's Constitution, statutes, common law, regulations, and sovereign immunity.

The Parties must comply with all applicable local, state, and federal laws, ordinances, rules, orders, and regulations.

**E. AMENDMENT**

This Contract may be amended in writing, within scope, upon the agreement of both parties.

**F. SUBSTITUTIONS**

Accept (Initial)	Reject (Initial)	Reject & Provide Alternative Response (Initial)	NOTES/COMMENTS:
CDL			

In the event any product is discontinued or replaced upon mutual consent during the contract period or prior to delivery, the State reserves the right to amend the contract or purchase order to include the alternate product which meets or exceeds original specifications and is the same or lesser price.

**\*\*\*Contractor will not substitute any item that has been awarded without prior written approval of SPB\*\*\***

**G. VENDOR PERFORMANCE REPORT(S)**

Accept (Initial)	Reject (Initial)	Reject & Provide Alternative Response (Initial)	NOTES/COMMENTS:
CDL			

The State may document any instance(s) of products or services delivered or performed which exceed or fail to meet the terms of the purchase order, contract, and/or solicitation specifications. The SPB may contact the Vendor regarding any such report. Vendor performance report(s) will become a part of the permanent record of the Vendor.

**H. NOTICE OF POTENTIAL VENDOR BREACH**

Accept (Initial)	Reject (Initial)	Reject & Provide Alternative Response (Initial)	NOTES/COMMENTS:
CDL			

If Vendor breaches the contract or anticipates breaching the contract, the Vendor shall immediately give written notice to the State. The notice shall explain the breach or potential breach, a proposed cure, and may include a request for a waiver of the breach if so desired. The State may, in its discretion, temporarily or permanently waive the breach. By granting a waiver, the State does not forfeit any rights or remedies to which the State is entitled by law or equity, or pursuant to the provisions of the contract. Failure to give immediate notice, however, may be grounds for denial of any request for a waiver of a breach.

**INVITATION TO BID  
Number 6736 OF**

**I. BREACH**

Accept (Initial)	Reject (Initial)	Reject & Provide Alternative Response (Initial)	NOTES/COMMENTS:
CDL			

Either Party may terminate the contract, in whole or in part, if the other Party breaches its duty to perform its obligations under the contract in a timely and proper manner. Termination requires written notice of default and a thirty (30)-calendar day (or longer at the non-breaching Party's discretion considering the gravity and nature of the default) cure period. Said notice shall be delivered through email. Allowing time to cure a failure or breach of contract does not waive the right to immediately terminate the contract for the same or different contract breach which may occur at a different time.

In case of breach by the Vendor, the State may, without unreasonable delay, make a good faith effort to make a reasonable purchase or contract to purchased goods in substitution of those due from the vendor. The State may recover from the Vendor as damages the difference between the costs of covering the breach. Notwithstanding any clause to the contrary, the State may also recover the contract price together with any incidental or consequential damages defined in UCC Section 2-715, but less expenses saved in consequence of Vendor's breach **OR** in case of default of the Vendor, the State may contract the service from other sources and hold the Vendor responsible for any excess cost occasioned thereby.

The State's failure to make payment shall not be a breach, and the Vendor shall retain all available statutory remedies.

**J. NON-WAIVER OF BREACH**

Accept (Initial)	Reject (Initial)	Reject & Provide Alternative Response (Initial)	NOTES/COMMENTS:
CDL			

The acceptance of late performance with or without objection or reservation by a Party shall not waive any rights of the Party nor constitute a waiver of the requirement of timely performance of any obligations remaining to be performed.

**K. SEVERABILITY**

Accept (Initial)	Reject (Initial)	Reject & Provide Alternative Response (Initial)	NOTES/COMMENTS:
CDL			

If any term or condition of the contract is declared by a court of competent jurisdiction to be illegal or in conflict with any law, the validity of the remaining Terms and Conditions shall not be affected, and the rights and obligations of the parties shall be construed and enforced as if the contract did not contain the provision held to be invalid or illegal.

**L. INDEMNIFICATION**

Accept (Initial)	Reject (Initial)	Reject & Provide Alternative Response (Initial)	NOTES/COMMENTS:
CDL			

**1. GENERAL**

The Contractor agrees to defend, indemnify, and hold harmless the State and its employees, volunteers, agents, and its elected and appointed officials ("the indemnified parties") from and against any and all claims, liens, demands, damages, liability, actions, causes of action, losses, judgments, costs, and expenses of every nature, including investigation costs and expenses, settlement costs, and attorney fees and expenses ("the claims"), sustained or asserted against the State for personal injury, death, or property loss or damage, arising out of, resulting from, or attributable to the willful misconduct, negligence, error, or omission of the Contractor, its employees, Subcontractors, consultants, representatives, and agents, resulting from this contract, except to the extent such Contractor liability is attenuated by any action of the State which directly and proximately contributed to the claims.

**INVITATION TO BID  
Number 6736 OF**

**2. SELF-INSURANCE (Statutory)**

The State is self-insured for any loss and purchases excess insurance coverage pursuant to Neb. Rev. Stat. § 81-8,239.01 (Reissue 2008). If there is a presumed loss under the provisions of this contract, Vendor may file a claim with the Office of Risk Management pursuant to Neb. Rev. Stat. §§ 81-8,829 through 81-8,306 for review by the State Claims Board. The State retains all rights and immunities under the State Miscellaneous (Section 81-8,294), Tort (Section 81-8,209), and Contract Claim Acts (Section 81-8,302), as outlined in Neb. Rev. Stat. § 81-8,209 et seq. and under any other provisions of law and accepts liability under this contract to the extent provided by law.

**M. ATTORNEY'S FEES**

Accept (Initial)	Reject (Initial)	Reject & Provide Alternative Response (Initial)	NOTES/COMMENTS:
CDL			

In the event of any litigation, appeal, or other legal action to enforce any provision of the contract, the Parties agree to pay all expenses of such action, as permitted by law and if ordered by the court, including attorney's fees and costs, if the other party prevails.

**N. ASSIGNMENT, SALE, OR MERGER**

Accept (Initial)	Reject (Initial)	Reject & Provide Alternative Response (Initial)	NOTES/COMMENTS:
CDL			

Either party may assign the contract upon mutual written agreement of the other party. Such agreement shall not be unreasonably withheld. The Vendor retains the right to enter into a sale, merger, acquisition, internal reorganization, or similar transaction involving Vendor's business. Vendor agrees to cooperate with the State in executing amendments to the contract to allow for the transaction. If a third party or entity is involved in the transaction, the Vendor will remain responsible for performance of the contract until such time as the person or entity involved in the transaction agrees in writing to be contractually bound by this contract and perform all obligations of the contract.

**O. CONTRACTING WITH OTHER POLITICAL SUB-DIVISIONS OF THE STATE OR ANOTHER STATE**

Accept (Initial)	Reject (Initial)	Reject & Provide Alternative Response (Initial)	NOTES/COMMENTS:
CDL			

The Vendor may, but shall not be required to, allow agencies, as defined in Neb. Rev. Stat. § 81-145, to use this contract. The Terms and Conditions, including price, of the contract may not be amended. The State shall not be contractually obligated or liable for any contract entered into pursuant to this clause.

The Vendor may, but shall not be required to, allow other states, agencies or divisions of other states, or political subdivisions of other states to use this contract. The Terms and Conditions, including price, of this contract shall apply to any such contract, but may be amended upon mutual consent of the Parties. The State of Nebraska shall not be contractually or otherwise obligated or liable under any contract entered into pursuant to this clause. The State shall be notified if a contract is executed based upon this contract.

**P. FORCE MAJEURE**

Accept (Initial)	Reject (Initial)	Reject & Provide Alternative Response (Initial)	NOTES/COMMENTS:
CDL			

Neither party shall be liable for any costs or damages, or for default resulting from its inability to perform any of its obligations under the contract due to a natural or man-made event outside the control and not the fault of the affected party ("Force Majeure Event"). The Party so affected shall immediately make a written request for relief to the other party and shall have the burden of proof to justify the request. The other Party may grant the relief requested; relief may not be unreasonably withheld. Labor disputes with the impacted party's own employees will not be considered a Force Majeure Event.

**INVITATION TO BID  
Number 6736 OF**

**Q. CONFIDENTIALITY**

Accept (Initial)	Reject (Initial)	Reject & Provide Alternative Response (Initial)	NOTES/COMMENTS:
CDL			

All materials and information provided by the Parties or acquired by a Party on behalf of the other Party shall be regarded as confidential information. All materials and information provided or acquired shall be handled in accordance with federal and state law, and ethical standards. Should said confidentiality be breached by a Party, the Party shall notify the other Party immediately of said breach and take immediate corrective action.

It is incumbent upon the Parties to inform their officers and employees of the penalties for improper disclosure imposed by the Privacy Act of 1974, 5 USC 552a. Specifically, 5 USC 552a (i)(1), which is made applicable by 5 USC 552a (m)(1), provides that any officer or employee, who by virtue of his/her employment or official position has possession of or access to agency records which contain individually identifiable information, the disclosure of which is prohibited by the Privacy Act or regulations established thereunder, and who knowing that disclosure of the specific material is prohibited, willfully discloses the material in any manner to any person or agency not entitled to receive it, shall be guilty of a misdemeanor and fined not more than \$5,000.00.

**R. EARLY TERMINATION**

Accept (Initial)	Reject (Initial)	Reject & Provide Alternative Response (Initial)	NOTES/COMMENTS:
CDL			

The contract may be terminated as follows:

1. The State and the Vendor, by mutual written agreement, may terminate the contract at any time.
2. The State, at its sole discretion, may terminate the contract for any reason upon 30 calendar day's written notice to the Vendor. Such termination shall not relieve the Vendor of warranty or other service obligations incurred under the terms of the contract. In the event of termination, the Vendor shall be entitled to payment, determined on a pro rata basis, for products or services satisfactorily performed or provided.
3. The State may terminate the contract immediately for the following reasons:
  - a. if directed to do so by statute;
  - b. Vendor has made an assignment for the benefit of creditors, has admitted in writing its inability to pay debts as they mature, or has ceased operating in the normal course of business;
  - c. a trustee or receiver of the Vendor or of any substantial part of the Vendor's assets has been appointed by a court;
  - d. fraud, misappropriation, embezzlement, malfeasance, misfeasance, or illegal conduct pertaining to performance under the contract by its Vendor, its employees, officers, directors, or shareholders;
  - e. an involuntary proceeding has been commenced by any party against the Vendor under any one of the chapters of Title 11 of the United States Code and (i) the proceeding has been pending for at least sixty (60) calendar days; or (ii) the Vendor has consented, either expressly or by operation of law, to the entry of an order for relief; or (iii) the Vendor has been decreed or adjudged a debtor;
  - f. a voluntary petition has been filed by the Vendor under any of the chapters of Title 11 of the United States Code;
  - g. Vendor intentionally discloses confidential information;
  - h. Vendor has or announces it will discontinue support of the deliverable; and,
  - i. In the event funding is no longer available.

**INVITATION TO BID  
Number 6736 OF**

**III. CONTRACTOR DUTIES**

**A. INDEPENDENT CONTRACTOR / OBLIGATIONS**

Accept (Initial)	Reject (Initial)	Reject & Provide Alternative Response (Initial)	NOTES/COMMENTS:
CDL			

It is agreed that the Vendor is an independent contractor and that nothing contained herein is intended or should be construed as creating or establishing a relationship of employment, agency, or a partnership.

The Vendor is solely responsible for fulfilling the contract. The Vendor or the Vendor's representative shall be the sole point of contact regarding all contractual matters.

The Vendor shall secure, at its own expense, all personnel required to perform the services under the contract. The personnel the Vendor uses to fulfill the contract shall have no contractual or other legal relationship with the State; they shall not be considered employees of the State and shall not be entitled to any compensation, rights, or benefits from the State, including but not limited to, tenure rights, medical and hospital care, sick and vacation leave, severance pay, or retirement benefits.

By-name personnel commitments made in the Vendor's bid shall not be changed without the prior written approval of the State. Replacement of these personnel, if approved by the State, shall be with personnel of equal or greater ability and qualifications.

The Vendor warrants that all persons assigned to the project shall be employees of the Vendor or a Subcontractor and shall be fully qualified to perform the work required herein. Personnel employed by the Vendor or a subcontractor to fulfill the terms of the contract shall remain under the sole direction and control of the Vendor or the subcontractor respectively.

With respect to its employees, the Vendor agrees to be solely responsible for the following:

1. Any and all pay, benefits, and employment taxes and/or other payroll withholding;
2. Any and all vehicles used by the Vendor's employees, including all insurance required by state law;
3. Damages incurred by Vendor's employees within the scope of their duties under the contract;
4. Maintaining Workers' Compensation and health insurance that complies with state and federal law and submitting any reports on such insurance to the extent required by governing law;
5. Determining the hours to be worked and the duties to be performed by the Vendor's employees; and,
6. All claims on behalf of any person arising out of employment or alleged employment (including without limit claims of discrimination alleged against the Vendor, its officers, agents, or subcontractors or subcontractor's employees).

If the Vendor intends to utilize any subcontractor, the Subcontractor's level of effort, tasks, and time allocation must be clearly defined in the Vendor's bid. The Vendor shall agree that it will not utilize any Subcontractors not specifically included in its bid in the performance of the contract without the prior written authorization of the State.

The State reserves the right to require the Vendor to reassign or remove from the project any Vendor or Subcontractor employee.

Vendor shall insure that the Terms and Conditions contained in any contract with a sub-contractor does not conflict with the Terms and Conditions of this contract.

The Vendor shall include a similar provision, for the protection of the State, in the contract with any Subcontractor engaged to perform work on this contract.

**B. EMPLOYEE WORK ELIGIBILITY STATUS**

The Vendor is required and hereby agrees to use a federal immigration verification system to determine the work eligibility status of employees physically performing work within the State. A federal immigration verification system means the electronic verification of the work authorization program authorized by the Illegal Immigration Reform and Immigrant Responsibility Act of 1996, 8 U.S.C. 1324a, known as the E-Verify Program, or an equivalent federal program designated by the United States Department of Homeland Security or other federal agency authorized to verify the work eligibility status of an employee.

If the Vendor is an individual or sole proprietorship, the following applies:

1. The Vendor must complete the United States Citizenship Attestation Form, available on the Nebraska Secretary of State website at [Microsoft Word - attestation\\_form,lor's\\_version.docx \(nebraska.gov\)](#)

**If required, the completed United States Attestation Form should be submitted with the solicitation response.**

**INVITATION TO BID  
Number 6736 OF**

2. If the Vendor indicates on such attestation form that he or she is a qualified alien, the Vendor agrees to provide the U.S. Citizenship and Immigration Services documentation required to verify the Vendor's lawful presence in the United States using the Systematic Alien Verification for Entitlements (SAVE) Program.
3. The Vendor understands and agrees that lawful presence in the United States is required, and the Vendor may be disqualified, or the contract terminated if such lawful presence cannot be verified as required by Neb. Rev. Stat. § 4-108.

**C. COMPLIANCE WITH CIVIL RIGHTS LAWS AND EQUAL OPPORTUNITY EMPLOYMENT / NONDISCRIMINATION (Statutory)**

The Vendor shall comply with all applicable local, state, and federal statutes and regulations regarding civil rights laws and equal opportunity employment. The Nebraska Fair Employment Practice Act prohibits Vendors of the State, and their Subcontractors, from discriminating against any employee or applicant for employment, with respect to hire, tenure, terms, conditions, compensation, or privileges of employment because of race, color, religion, sex, disability, marital status, or national origin (Neb. Rev. Stat. §§ 48-1101 through 48-1125). The Vendor guarantees compliance with the Nebraska Fair Employment Practice Act, and breach of this provision shall be regarded as a material breach of contract. The Vendor shall insert a similar provision in all Subcontracts for goods or services to be covered by any contract resulting from this solicitation.

**D. COOPERATION WITH OTHER CONTRACTORS**

Accept (Initial)	Reject (Initial)	Reject & Provide Alternative Response (Initial)	NOTES/COMMENTS:
CDL			

Vendor may be required to work with or in close proximity to other vendors or individuals that may be working on the same or different projects. The Vendor shall agree to cooperate with such other vendors or individuals and shall not commit or permit any act which may interfere with the performance of work by any other vendor or individual. Vendor is not required to compromise Vendor's intellectual property or proprietary information unless expressly required to do so by this contract.

**E. DISCOUNTS**

Prices quoted shall be inclusive of ALL trade discounts. Cash discount terms of less than thirty (30) days will not be considered as part of the bid. Cash discount periods will be computed from the date of receipt of a properly executed claim voucher or the date of completion of delivery of all items in a satisfactory condition, whichever is later.

**F. PRICES**

Prices quoted shall be net, including transportation and delivery charges fully prepaid by the vendor, FOB destination named in the solicitation. No additional charges will be allowed for packing, packages, or partial delivery costs. When an arithmetic error has been made in the extended total, the unit price will govern.

All prices, costs, and Terms and Conditions submitted in the bid shall remain fixed and valid commencing on the opening date of the bid through the first one hundred eighty (180) days of the contract.

Any Price Increase Request must be submitted, in writing to SPB a minimum of thirty (30) days prior to the proposed effective date of increase and be accompanied by supporting documentation.

1. Several forms of justification documentation may be required by the State to authenticate the increase;
2. Failure to supply any requested justification documentation may be grounds to cancel the contract;
3. The State further reserves the right to reject any proposed price increase(s), cancel the contract and re-bid if determined to be in the best interest of the State;
4. No price increases shall be billed to any State Agencies prior to written Amendment of the contract by the parties;
5. The State will be given full proportionate benefit of any decrease for the term of the contract; and,
6. Contract supplier(s) may honor pricing and extend the contract to political sub-divisions, cities, and counties as long as the Contract Terms and Conditions are met.

**G. COST CLARIFICATION**

The State reserves the right to review all aspects of cost for reasonableness and to request clarification of any bid where the cost component shows significant and unsupported deviation from industry standards or in areas where detailed pricing is required.



**INVITATION TO BID  
Number 6736 OF**

**H. PERMITS, REGULATIONS, LAWS**

Accept (Initial)	Reject (Initial)	Reject & Provide Alternative Response (Initial)	NOTES/COMMENTS:
CDL			

The contract price shall include the cost of all royalties, licenses, permits, and approvals, whether arising from patents, trademarks, copyrights or otherwise, that are in any way involved in the contract. The Vendor shall obtain and pay for all royalties, licenses, and permits, and approvals necessary for the performance of the contract. The Vendor must guarantee that it has the full legal right to the materials, supplies, equipment, software, and other items used to execute this contract.

**I. NOTICE OF POTENTIAL VENDOR BREACH**

Accept (Initial)	Reject (Initial)	Reject & Provide Alternative Response (Initial)	NOTES/COMMENTS:
CDL			

If Vendor breaches the contract or anticipates breaching the contract the Vendor shall immediately give written notice to the State. The notice shall explain the breach or potential breach and may include a request for a waiver of the breach if so desired. The State may, at its discretion, temporarily or permanently waive the breach. By granting a temporary waiver, the State does not forfeit any rights or remedies to which the State is entitled by law or equity, or pursuant to the provisions of the contract. Failure to give immediate notice, however, may be grounds for denial of any request for a waiver of a breach.

**J. ANTITRUST**

Accept (Initial)	Reject (Initial)	Reject & Provide Alternative Response (Initial)	NOTES/COMMENTS:
CDL			

The Vendor hereby assigns to the State any and all claims for overcharges as to goods and/or services provided in connection with this contract resulting from antitrust violations which arise under antitrust laws of the United States and the antitrust laws of the State.

**K. CONFLICT OF INTEREST**

Accept (Initial)	Reject (Initial)	Reject & Provide Alternative Response (Initial)	NOTES/COMMENTS:
CDL			

By submitting a bid, bidder certifies that no relationship exists between the bidder and any person or entity which either is, or gives the appearance of, a conflict of interest related to this ITB.

Bidder further certifies that bidder will not employ any individual known by bidder to have a conflict of interest nor shall bidder take any action or acquire any interest, either directly or indirectly, which will conflict in any manner or degree with the performance of its contractual obligations hereunder or which creates an actual or appearance of conflict of interest.

If there is an actual or perceived conflict of interest, bidder shall provide with its bid a full disclosure of the facts describing such actual or perceived conflict of interest and a proposed mitigation plan for consideration. The State will then consider such disclosure and proposed mitigation plan and either approve or reject as part of the overall bid evaluation.

**INVITATION TO BID  
Number 6736 OF**

**L. SITE RULES AND REGULATIONS**

Accept (Initial)	Reject (Initial)	Reject & Provide Alternative Response (Initial)	NOTES/COMMENTS:
CDL			

The Vendor shall use its best efforts to ensure that its employees, agents, and Subcontractors comply with site rules and regulations while on State premises. If the Vendor must perform on-site work outside of the daily operational hours set forth by the State, it must make arrangements with the State to ensure access to the facility and the equipment has been arranged. No additional payment will be made by the State on the basis of lack of access, unless the State fails to provide access as agreed to in writing between the State and the Vendor.

**M. ADVERTISING**

Accept (Initial)	Reject (Initial)	Reject & Provide Alternative Response (Initial)	NOTES/COMMENTS:
CDL			

The Vendor agrees not to refer to the contract award in advertising in such a manner as to state or imply that the company or its goods and services are endorsed or preferred by the State. Any publicity releases pertaining to the project shall not be issued without prior written approval from the State.

**N. NEBRASKA TECHNOLOGY ACCESS STANDARDS (Statutory)**

Vendor shall review the Nebraska Technology Access Standards, found at <http://nitc.nebraska.gov/standards/2-201.html> and ensure that products and/or goods provided under the contract are in compliance or will comply with the applicable standards to the greatest degree possible. In the event such standards change during the Vendor's performance, the State may create an amendment to the contract to request the contract comply with the changed standard at a cost mutually acceptable to the parties.

**O. DISASTER RECOVERY/BACK UP PLAN**

Accept (Initial)	Reject (Initial)	Reject & Provide Alternative Response (Initial)	NOTES/COMMENTS:
CDL			

The Vendor shall have a disaster recovery and back-up plan, of which a copy should be provided upon request to the State, which includes, but is not limited to equipment, personnel, facilities, and transportation, in order to continue delivery of goods and services as specified under the specifications in the contract in the event of a disaster.

**P. DRUG POLICY**

Accept (Initial)	Reject (Initial)	Reject & Provide Alternative Response (Initial)	NOTES/COMMENTS:
CDL			

Vendor certifies it maintains a drug free workplace environment to ensure worker safety and workplace integrity. Vendor agrees to provide a copy of its drug free workplace policy at any time upon request by the State.

**Q. WARRANTY**

Accept (Initial)	Reject (Initial)	Reject & Provide Alternative Response (Initial)	NOTES/COMMENTS:
CDL			

Despite any clause to the contrary, the Vendor represents and warrants that its services hereunder shall be performed by competent personnel and shall be of professional quality consistent with generally accepted industry standards for the performance of such services and shall comply in all respects with the requirements of this Contract. For any breach of this

**INVITATION TO BID  
Number 6736 OF**

warranty, the Vendor shall, for a period of ninety (90) days from performance of the service, perform the services again, at no cost to Customer, or if Vendor is unable to perform the services as warranted, Vendor shall reimburse Customer the fees paid to Vendor for the unsatisfactory services. The rights and remedies of the parties under this warranty are in addition to any other rights and remedies of the parties provided by law or equity, including, without limitation actual damages, and, as applicable and awarded under the law, to a prevailing party, reasonable attorneys' fees, and costs.

**INVITATION TO BID  
Number 6736 OF**

**IV. PAYMENT**

**A. PROHIBITION AGAINST ADVANCE PAYMENT (Statutory)**

Neb. Rev. Stat. § 81-2403 states, “[n]o goods or services shall be deemed to be received by an agency until all such goods or services are completely delivered and finally accepted by the agency.”

**B. TAXES (Statutory)**

The State is not required to pay taxes and assumes no such liability as a result of this solicitation. The Vendor may request a copy of the Nebraska Department of Revenue, Nebraska Resale or Exempt Sale Certificate for Sales Tax Exemption, Form 13 for their records. Any property tax payable on the Vendor's equipment which may be installed in a state-owned facility is the responsibility of the Vendor.

**C. INVOICES**

Invoices for payments must be submitted by the Contractor to the agency requesting the services with sufficient detail to support payment. The terms and conditions included in the Contractor's invoice shall be deemed to be solely for the convenience of the parties. No terms or conditions of any such invoice shall be binding upon the State, and no action by the State, including without limitation the payment of any such invoice in whole or in part, shall be construed as binding or estopping the State with respect to any such term or condition, unless the invoice term or condition has been previously agreed to by the State as an amendment to the contract.

**D. INSPECTION AND APPROVAL**

Accept (Initial)	Reject (Initial)	Reject & Provide Alternative Response (Initial)	NOTES/COMMENTS:
CDL			

Final inspection and approval of all work required under the contract shall be performed by the designated State officials. The State and/or its authorized representatives shall have the right to enter any premises where the Vendor or Subcontractor duties under the contract are being performed, and to inspect, monitor or otherwise evaluate the work being performed. All inspections and evaluations shall be at reasonable times and in a manner that will not unreasonably delay work.

**E. PAYMENT (Statutory)**

Payment will be made by the responsible agency in compliance with the State of Nebraska Prompt Payment Act (See Neb. Rev. Stat. § 81-2403). The State may require the Vendor to accept payment by electronic means such as ACH deposit. In no event shall the State be responsible or liable to pay for any goods and services provided by the Vendor prior to the Effective Date of the contract, and the Vendor hereby waives any claim or cause of action for any such services.

**F. LATE PAYMENT (Statutory)**

The Vendor may charge the responsible agency interest for late payment in compliance with the State of Nebraska Prompt Payment Act (See Neb. Rev. Stat. §§ 81-2401 through 81-2408).

**G. SUBJECT TO FUNDING / FUNDING OUT CLAUSE FOR LOSS OF APPROPRIATIONS (Statutory)**

The State's obligation to pay amounts due on the Contract for a fiscal year following the current fiscal year is contingent upon legislative appropriation of funds. Should said funds not be appropriated, the State may terminate the contract with respect to those payments for the fiscal year(s) for which such funds are not appropriated. The State will give the Vendor written notice thirty (30) calendar days prior to the effective date of termination. All obligations of the State to make payments after the termination date will cease. The Vendor shall be entitled to receive just and equitable compensation for any authorized work which has been satisfactorily completed as of the termination date. In no event shall the Vendor be paid for a loss of anticipated profit.

**H. RIGHT TO AUDIT (First Paragraph is Statutory)**

Accept (Initial)	Reject (Initial)	Reject & Provide Alternative Response (Initial)	NOTES/COMMENTS:
CDL			

The State shall have the right to audit the Vendor's performance of this contract upon thirty (30) days written notice. Vendor shall utilize generally accepted accounting principles, and shall maintain the accounting records, and other records and information relevant to the contract (Information) to enable the State to audit the contract. (Neb. Rev. Stat. § 84-304 et seq.) The State may audit, and the Vendor shall maintain the information during the term of the contract and for a period of five (5) years after the completion of this contract or until all issues or litigation are resolved, whichever is later. The Vendor shall make the Information available to the State at Vendor's place of business or a location acceptable to both Parties during normal business hours. If this is not practical or the Vendor so elects, the Vendor may provide electronic or paper copies of the

**INVITATION TO BID**  
**Number 6736 OF**

Information. The State reserves the right to examine, make copies of, and take notes on any Information relevant to this contract, regardless of the form or the Information, how it is stored, or who possesses the Information. In no circumstances will vendor be required to create or maintain documents not kept in the ordinary course of vendor's business operations, nor will vendor be required to disclose any information, including but not limited to product cost data, which is confidential or proprietary to vendor.

The Parties shall pay their own costs of the audit unless the audit finds a previously undisclosed overpayment by the State. If a previously undisclosed overpayment exceeds one-half of one percent (.5%) of the total contract billings, or if fraud, material misrepresentations, or non-performance is discovered on the part of the Vendor, the Vendor shall reimburse the State for the total costs of the audit. Overpayments and audit costs owed to the State shall be paid within 90 days of written notice of the claim. The Vendor agrees to correct any material weaknesses or condition found as a result of the audit.

**INVITATION TO BID**  
**Number 6736 OF**

**V. SCOPE OF WORK**

The Vendor must provide the following information in response to this solicitation.

**A. SCOPE**

It is the intent of this bid to establish a contract to supply **2023 or Current Production Year Ford Transit XLT Side Lift All Wheel Drive (AWD) Transit Vans** per the attached specifications from date of award for a period of one (1) year with the option to renew for an additional four (4), one (1) year periods when mutually agreeable to the vendor and the State. The State reserves the right to extend the period of this contract beyond the end date when mutually agreeable to the vendor and the State.

All items proposed shall be of the latest manufacture in production as of the date of the solicitation and be of proven performance and under standard design complete as regularly advertised and marketed. All necessary materials for satisfactory performance of the supplies shall be incorporated into the **2023 or Current Production Year Ford Transit XLT Side Lift All Wheel Drive (AWD) Transit Vans** whether or not they may be specifically mentioned below.

Complete specifications, manufacturer's current descriptive literature and/or advertising data sheets with cuts or photographs must be included with the bid for the IDENTICAL items proposed. Any information necessary to show compliance with these specifications not given on the manufacturer's descriptive literature and/or advertising data sheets must be supplied in writing on or attached to the bid document. If manufacturer's information necessary to show compliance with these specifications is not attached to the bid document, the Vendor may be required to submit requested information within three (3) business days of a written request. Failure to submit requested descriptive literature or advertising data sheets may be grounds to reject the bid.

**INVITATION TO BID  
Number 6736 OF**

**VI. TECHNICAL SPECIFICATIONS**

**A. VENDOR INSTRUCTIONS**

Vendor must respond to each of the following statements. Specifications listed are minimum conditions that must be met in order for a Vendor to qualify for the award.

“YES” response means the Vendor guarantees they can meet this condition.

“NO” response means the Vendor cannot meet this condition and will not be considered.

“NO & PROVIDE ALTERNATIVE” responses should be used only with a narrative response in the “NOTES/COMMENTS” section explaining in detail any deviation from the Vendor’s ability to meet the condition, and an explanation of how this would be determined to be an acceptable alternative to meeting the condition.

**Alternative responses must be detailed in such a way that allows such deviations to be fully evaluated. The State shall determine at its sole discretion whether or not the Vendor’s alternative is an acceptable alternative.**

**B. MANUFACTURER’S MINIMUM SPECIFICATIONS**

YES	NO	NO & PROVIDE ALTERNATIVE	
CDL			1. Because the Ford Motor Company had not released their complete line of Minimum Specifications at the time these specifications were defined, the Minimum Specifications are based off the Manufacturer’s 2022 specifications.
<b>NOTES/COMMENTS:</b>			

**C. NON-COMPLIANCE STATEMENT**

YES	NO	NO & PROVIDE ALTERNATIVE	
CDL			1. Read these specifications carefully. Any and all exceptions to these specifications must be written on or attached to solicitation response. Any noncompliance may void your bid. Non-compliance to any single specification can void your bid.
CDL			2. It is the responsibility of Vendors to obtain information and clarifications as provided below. The State is not responsible for any erroneous or incomplete understandings or wrongful interpretations of this solicitation by any Vendor.
CDL			3. No interpretation related to the meaning of solicitation specifications or other pre-bid documents will be made orally to any Vendor by the State.
CDL			4. The Vendor must submit any solicitation interpretation in writing to SPB via the following ShareFile link: <a href="https://nebraska.sharefile.com/r-r127a26ed662440ee9facec2e361d8017">https://nebraska.sharefile.com/r-r127a26ed662440ee9facec2e361d8017</a> by the last day to submit written questions per the Schedule of Events. (Inquiries received after the last day to submit written questions may not be addressed).
<b>NOTES/COMMENTS:</b>			

**D. CODE OF FEDERAL REGULATIONS FMVSS**

YES	NO	NO & PROVIDE ALTERNATIVE	
CDL			1. The Code of Federal Regulations mentioned in this Section are in addition to the specifications contained in this ITB.
CDL			2. All vehicles bid must meet the guidelines established in the Code of Federal Regulations, Title 49, Subtitle B, Chapter V, Part 571 FMVSS found at the following link:  <a href="https://www.ecfr.gov/current/title-49/subtitle-B/chapter-V/part-571?toc=1">https://www.ecfr.gov/current/title-49/subtitle-B/chapter-V/part-571?toc=1</a>

**INVITATION TO BID  
Number 6736 OF**

NOTES/COMMENTS:

**E. MOTOR VEHICLE INDUSTRIES REGULATION ACT**

YES	NO	NO & PROVIDE ALTERNATIVE	
CDL			1. All Vendors must comply with the licensing requirements for motor vehicle dealers established under the Motor Vehicle Industries Regulation Act, Nebraska Revised Statutes, Chapter 60, Article 14 at time of bid. Bids will only be accepted from Vendors who are fully compliant with the Motor Vehicle Industries Regulation Act, Chapter 60, Article 14.
NOTES/COMMENTS:			

**F. MISCELLANEOUS SPECIFICATIONS**

YES	NO	NO & PROVIDE ALTERNATIVE	
CDL			1. The manufacturer of the vehicle body must be certified to be in compliance with Quality Standards of the ISO 9001:2000 with regard to the sale, design, and Manufacturer of the vehicle.
CDL			2. Bidder must provide proof that the Manufacturer is ISO certified by submitting a copy of the manufacturer's ISO Certification with their bid or before award.
CDL			3. Must provide public transportation in light transit or paratransit service for ambulatory, non-ambulatory, physically, and mentally handicapped passengers primarily in rural and small urban areas.
CDL			4. Must operate in ambient temperatures ranging from -25° to +115° F for extended periods of time.
NOTES/COMMENTS:			

**G. DIMENSIONS AND CAPACITY**

YES	NO	NO & PROVIDE ALTERNATIVE	
CDL			1. GVWR shall be a minimum of 10,360 lbs. and have a payload of 3,100 lbs. for each wheelchair space provided.
			2. <b>Must accommodate the following combinations:</b>
CDL			a. The driver
CDL			b. A wheelchair lift
CDL			c. A minimum of two (2) passengers seated in standard wheelchairs.
CDL			d. A minimum of six (6) ambulatory passengers seated in regular seats with two (2) passengers seated in standard wheelchairs on board.
CDL			e. A minimum of nine (9) ambulatory passengers without passengers in wheelchairs.
CDL			3. The Interior Headroom measured from floor to ceiling shall be a minimum of 56" for the first row of seating and a maximum of 66" for any row of seating.
CDL			4. The Interior width of the vehicle shall be a minimum of 60" an a maximum of 70".
CDL			5. The Exterior width, excluding exterior mirrors, shall be 83.7".
CDL			6. The exterior height, including the safety vent, shall be a minimum of 107.7".



**INVITATION TO BID  
Number 6736 OF**

CDL			7.	A "Vehicle Clearance Sticker" indicating the maximum height of the vehicle in feet and inches shall be affixed in the interior of the vehicle, above the windshield and located where it is easily viewed by the driver.
CDL			8.	The Wheelbase shall be a minimum of 147.6"
CDL			9.	The overall length of the vehicle shall be a minimum of 240" and a maximum of 264".
CDL			10.	All entry stairs shall be a maximum of 12" above ground level.
CDL			11.	Any subsequent stair risers shall be a maximum of 10".
<b>NOTES/COMMENTS:</b>				

**H. CHASSIS AND RELATED SYSTEMS**

YES	NO	NO & PROVIDE ALTERNATIVE		
CDL			1.	2023 or Current Production Year unibody van chassis with GVWR of 10,360 lbs.
CDL			2.	The minimum Engine size is 3.5L V6 gasoline turbocharged.
CDL			3.	Manufacturer's heavy duty, increased capacity coolant system for protection to 30 degrees below zero Fahrenheit.
CDL			4.	Manufacturer recommended power tilt steering wheel with cruise control.
CDL			5.	Steering wheel with cruise control.
CDL			6.	Manufacturer's recommended power service brakes designed for the GVWR of the vehicle.
CDL			7.	Equipped with climate control, engine cooling systems, oils, greases, and fluids used in subsystems of the vehicle and wheelchair lifts
CDL			8.	Automatic Transmission.
CDL			9.	Manufacturer's recommended differential gear ratio.
CDL			10.	Both front and rear heavy-duty shock absorbers are required.
			11.	<b>Tires:</b>
CDL			a.	To be equipped with two (2) front and two (2) dual rear matching radial tires for a total of six (6) tires designed for the GVWR of the vehicle.
CDL			b.	The inner dual rear wheels are to be equipped with a solid brass air valve extension or braided stainless steel "live stem" air valve extension hose with a minimum rating of 120 psi, to be held together with securement clamps.
CDL			c.	Valve extensions should not extend beyond the outer edge of the rim of the outside dual rear wheels.
			12.	<b>Wheels:</b>
CDL			a.	To be equipped with four (4) matching minimum 16" minimum wheels.
CDL			b.	Wheels may be steel.
CDL			c.	The color of all wheels shall be compatible to the exterior color of the vehicle.
CDL			13.	The fuel tank shall be a minimum of 25 gallons.
CDL			14.	Manufacturer's standard bumper.
	CDL		15.	Front tow hooks required.
CDL			16.	An auto-throttle system capable of sensing when the electrical current draw exceeds alternator output and increases the engine idle RPM while the vehicle is stationary.
CDL			17.	Alternator shall be a minimum of 130 amperes.

**INVITATION TO BID  
Number 6736 OF**

CDL		18.	Manufacturer's heavy-duty dual batteries
CDL		19.	Back-up alarm required.
CDL		20.	Manufacturer's original equipment Back-up Camera with standard monitor.
CDL		21.	Front and rear rubber mud flaps required.
CDL		22.	The vehicle shall have street side exhaust system, which exits from the left side of vehicle, behind the rear axle and a minimum of 3" ahead of the rear bumper.
CDL		23.	If the vehicle's exhaust system should run closer than 8" to the fuel tank it must have metal heat shields or clamp on heat shield jacket between the exhaust and fuel tank.
CDL		24.	The vehicle shall be equipped with leaf spring rear suspension.
<b>NOTES/COMMENTS:</b> H-15. Front Tow hooks not available from OEM			

**I. AUXILIARY SYSTEMS, MISCELLANEOUS PARTS, AND ACCESSORIES**

YES	NO	NO & PROVIDE ALTERNATIVE	
CDL			1. The exterior lighting system shall conform to the requirements of <a href="#">FMVSS No. 108</a> and <a href="#">49 CFR Part 38 Subpart B 38.31</a> .
			<b>2. Interior Lighting:</b>
CDL			a. The interior lighting system shall provide bright floor surface illumination in the entryway, when required.
CDL			b. A separate overhead lamp shall be provided for the driver's use.
CDL			c. All lamps shall operate with or without the engine running.
CDL			d. The entrance steps shall automatically illuminate whenever the entrance doors are open, day or night, and conform <a href="#">to 49 CFR Part 38 Subpart B 38.31</a> .
CDL			3. Emergency flashers shall utilize turn signal bulbs in lieu of the brake light bulbs, so the emergency flashers will work when the brake pedal is depressed.
CDL			4. The controls for both the heater and air conditioner shall be easily accessible to the driver while seated with seat belts fastened.
			<b>5. Heating and Defrosting System:</b>
CDL			a. Shall have at least one (1) heating unit.
CDL			b. Shall have adjustable controls.
CDL			c. Includes windshield defrosting and defogging system.
CDL			6. Factory installed, individually adjustable, output Air Conditioning System.
CDL			7. Equipped with Climate control.
CDL			8. Dual, electrically driven wipers and washers shall be furnished with intermittent wipe and washing fluid reservoir shall have a minimum capacity of one (1) quart.
CDL			9. The Rearview Mirrors shall conform to the requirements of <a href="#">FMVSS 571.111</a> .
CDL			10. Fully adjustable driver's interior sun visor which shall not interfere with the driver's view of the rearview mirrors.
CDL			11. OEM horn.
CDL			12. Instrumentation shall include an oil pressure gauge, a coolant temperature gauge, a charge indicator with graduated charge-discharge scale, and an engine hour meter.
			<b>13. Radio and Speaker System:</b>

**INVITATION TO BID  
Number 6736 OF**

CDL			a. A ten (10)-watt minimum power output, push-button AM-FM stereo clock radio shall be provided.
CDL			b. The radio should be OEM, have Bluetooth connectivity and at least two (2) USB ports.
CDL			c. A minimum of four (4) speakers shall be included. Two (2) speakers in the front of the van and two (2) speakers in the rear.
CDL			14. A blind spot system shall be provided.
<b>NOTES/COMMENTS:</b>			

**J. EMERGENCY EQUIPMENT**

YES	NO	NO & PROVIDE ALTERNATIVE	
CDL			1. A 12-unit first aid kit, including instructions for contents shall be securely mounted in a location easily accessible to the driver while seated with seat belt fastened.
CDL			2. A UL approved fire extinguisher, minimum of five (5) lbs. with a minimum total rating of 2A, 10-B:C or UL Equivalent, shall be bracket mounted in a location easily accessible to the driver while seated with seat belt fastened
CDL			3. A kit of three (3) folding bi-directional emergency reflective triangles which conform to the requirements of <a href="#">FMVSS No. 125</a> shall be provided.
CDL			4. A dual purpose, safety, low profile, exterior roof vent which has an exterior maximum height of 2" above the vehicle roof, near the middle of the passenger compartment and mounted per manufacturer guidelines
CDL			5. Roof Hatch shall include gasket to seal out moisture.
CDL			6. Bloodborne Pathogens Kit shall contain latex gloves, CPR mask, goggles, apron, disinfectant wipes, absorbent and scoop, and an I.D. tag and red plastic bag at a minimum.
<b>NOTES/COMMENTS:</b>			

**K. INTERIOR FLOORING & SURFACES**

YES	NO	NO & PROVIDE ALTERNATIVE	
CDL			1. All materials used in the passenger compartment, including upholstery, padding, floor covering, and insulation shall conform to the requirements of <a href="#">FMVSS No. 302</a> .
CDL			2. Materials that emit toxic gases as byproducts of combustion shall not be used.
CDL			3. Floor covering shall be slip resistant exceeding the ADA minimum slip resistance standard rating of .06 static coefficient of friction, under dry or wet conditions.
CDL			4. Floor covering shall be constructed with aluminum oxide, silicon carbide, quartz and optional PVC chip blended throughout a high-quality vinyl wear surface (top coating is not acceptable).
CDL			5. Backing to be polyester cellulose material with fiberglass fiber reinforced center scrim for additional durability.
CDL			6. Floor covering shall be Meta 2.2 mm or greater, color TFM22903 Storm by Altro Transflor or Equivalent.
CDL			7. The entire floor will be a uniform thickness throughout the vehicle, eliminating the need for ribbed surfaces.
CDL			8. Seams are to be heat welded to provide a permanent waterproof seal against water penetration.
CDL			9. All trim edges (if used) are to be sealed by heat welding or with mastic/caulk by the manufacturer's instructions before installation.
CDL			10. Floor covering is to be installed on the passenger entrance steps and risers according to the manufacturer's recommendations.
CDL			11. Step edging shall be yellow vinyl step nosing installed according to the floor covering manufacture's recommendations.

**INVITATION TO BID  
Number 6736 OF**

CDL			12. Those interior surfaces that are not padded or covered with a decorative vinyl surface shall be appropriately primed and finished with a top-quality Acrylic enamel.
CDL			13. Color of paint and other interior finishing materials shall match the vehicle's exterior finish.
<b>NOTES/COMMENTS:</b>			

**L. MODULAR TRACK FLOORING**

YES	NO	NO & PROVIDE ALTERNATIVE	
CDL			1. Flooring shall be installed to include a series of longitudinal, parallel floor mounted, high-strength tracks/slots which are embedded into an <a href="#">FMVSS 302</a> compliant base.
CDL			2. The flooring system must allow for the rapid movement or removal of <a href="#">FMVSS 207 and 210</a> compliant ambulatory seating as well as "L" style wheelchair tie downs.
CDL			3. Tracks must provide incremental position options for tie-downs and seats.
		CDL	4. Seat latching system must be provided with a redundant, secondary mechanism to reduce the risk of unintended unlatching of the seat.
		CDL	5. Vehicle modifier (Bidder) shall provide documentation of "in-vehicle" testing performed on the floor system that complies with all FMVSS regulations pertaining to seat installation and wheelchair securement devices.
CDL			6. Floor shall be primed and adhered/connected to the primed vehicle metal floor using bolts connected to the chassis or using of a moisture curing and appropriate strength adhesive.
CDL			7. All edges will be properly sealed to prevent entrance of moisture.
CDL			8. Steel elements of the flooring system must be plated with a zinc chromate finish, thus providing maximum strength and corrosion resistance.
			9. <b>Anti-corrosion Treatment:</b>
CDL			10. All interior and exterior metal body components, including the interior body panels and posts, are to be covered by insulation or trim materials and protected against corrosion by bonderizing or an Equivalent process.
CDL			11. All nuts, bolts, clips, washers, clamps, and like fasteners shall be plated or phosphate-coated to prevent corrosion.
CDL			12. The ceiling and all interior walls of the vehicle shall contain thermal and acoustic insulation with a minimum R-5 rating and be moisture proof.
CDL			13. The entire body/frame under-structure of the vehicle shall be undercoated with nonflammable, resin-type material, polyoleum, or the Equivalent.
<b>NOTES/COMMENTS:</b> P-4. As an alternative we will install 2 single integrated child seats P-5. As alternative we will install 10 singel intergrated child seats			

**M. EXTERIOR FINISH**

YES	NO	NO & PROVIDE ALTERNATIVE	
CDL			1. All exterior metal body components are to be covered by insulation or trim materials and shall be protected against corrosion by bonderizing or an Equivalent process.
CDL			2. The exterior color shall be white.
CDL			3. Exterior surfaces shall be properly cleaned and primed prior to paint application.
CDL			4. Paint shall be applied smoothly and evenly free of dirt, runs, orange peel, and any other imperfections.
CDL			5. Vehicles that have been wrecked or sustained more than minor nicks and scratches will not be accepted.
CDL			6. The Vendor should not attempt to deliver a unit until minor nicks and scratches have been repaired.

**INVITATION TO BID  
Number 6736 OF**

<b>NOTES/COMMENTS:</b>
------------------------

**N. WINDSHIELD AND WINDOWS**

YES	NO	NO & PROVIDE ALTERNATIVE	
CDL			1. All glazing materials shall conform to the requirements of <a href="#">FMVSS No. 205</a> .
CDL			2. OEM standard all-around, fixed windows shall be furnished.
<b>NOTES/COMMENTS:</b>			

**O. DOORS**

YES	NO	NO & PROVIDE ALTERNATIVE	
CDL			1. The front passenger entrance door shall be a conventional/regular door.
CDL			2. The driver entrance door shall be a conventional/regular door with roll-down window and exterior key lock.
CDL			3. A full-length OEM driver's side running board to support a minimum of 325 lbs. shall be provided.
CDL			4. A full-length length OEM passenger door running board to support a minimum of 325 lbs. shall be provided.
CDL			5. A sliding door with a minimum opening width of 51.2" and a minimum opening height of 63".
			<b>6. Rear Doors:</b>
CDL			a. The rear door shall be split-type, outward-opening doors.
CDL			b. Both rear doors shall be fitted with latching mechanisms to secure each door when closed.
CDL			c. One rear door shall have a locking latch which allows both doors to be securely locked when closed.
<b>NOTES/COMMENTS:</b>			

**P. SEATS AND AISLE**

YES	NO	NO & PROVIDE ALTERNATIVE	
			<b>1. OEM Standard Driver and Front Passenger Seats:</b>
CDL			a. To have two (2)-way mechanical adjustable lumbar support.
CDL			b. To have four (4)-way adjustable headrests.
CDL			c. Adjustable flip-up armrests on both sides of seats.
CDL			2. All seatbelt assembly and seatbelt anchorages shall conform to the requirements of <a href="#">FMVSS 209</a> and <a href="#">FMVSS 210</a> .
			<b>3. Nine (9) Rear Passenger Seats:</b>
CDL			a. All cloth Freedman Featherweight rear passenger seats.
CDL			b. Color of rear passenger seat fabric shall be NPF by CMI Enterprises #831 Pinwheel Mono Blue or Equivalent treated with an anti-microbial coating such as Nanocide.

**INVITATION TO BID  
Number 6736 OF**

CDL			c. Grab handles positioned on top of mid-back or mid-hi seats.
CDL			d. Lumbar support fit on mounting track.
CDL			e. Back height of seats shall be a minimum of 22" from the top of the seat cushion.
CDL			f. Each passenger seating position shall be equipped with an under seat retractor seat belt assembly and belt anchorages that conform to the requirements of <b>FMVSS Nos. 209 and FMSS 210</b> .
CDL			g. The horizontal distance from the back of one seat to the front of the seat cushion directly behind the back of said seat or other obstruction shall be no less than 10".
CDL			h. Five (5) seats shall have adjustable flip-up armrests on left side of the seat.
CDL			i. Four (4) seats shall have adjustable flip-up armrests on the right side of the seat.
CDL			j. Flip-up US armrests shall be installed on each seat as follows: Five (5) seats shall each have one (1) left-side armrest. Four (4) seats shall each have one (1) right-side armrest.
CDL			k. Seat mountings must be compatible with the flooring specifications described in Subsection I-INTERIOR FINISH.
			<b>4. Dual Integrated Child Seating to consist of:</b>
CDL			a. One (1) flip up armrest.
CDL			b. Under seat retractor seatbelts.
			<b>5. Optional Dual Integrated Child Seat Configurations:</b>
CDL			a. The removal of the nine (9) rear passenger seats and replacing them with five (5) dual integrated child seats to provide seating for up to 10. Each dual seating child seat shall have:
CDL			i. One (1) each of the child restraint seats shall additionally be fitted with infant seat latch hooks compliant with <b>FMVSS 213 and 225</b> and be installed on the wall side of the dual passenger seats.
CDL			<b>6.</b> There must be at least two (2) potential wheelchair positions, each a minimum of 30" wide and 48" long while accommodating six (6) additional seated passengers.
<b>NOTES/COMMENTS:</b>			

**Q. WHEELCHAIR ACCOMMODATION**

YES	NO	NO & PROVIDE ALTERNATIVE	
			<b>1. Side Door Access:</b>
CDL			a. The sliding side door must be able to accommodate both a wheelchair lift and entry and exit for ambulatory passengers.
CDL			b. An interlock shall be provided to disable all lift controls whenever the doors are closed.
			<b>2. Wheelchair Lift:</b>
CDL			a. A 12-volt, fully automatic, electrohydraulic, or electromechanical, folding platform wheelchair lift with a design load of 800 lbs. shall be installed inside the side passenger door.
CDL			b. The platform lift shall be certified by the manufacturer to meet the requirements of <b>FMVSS 49 CFR Part 38</b> .
CDL			c. Please specify the brand name and model number of the lift being bid in the "NOTES/COMMENTS" section below.
CDL			d. When in the stowed configuration, all parts of the lift shall be completely housed within the vehicle.

**INVITATION TO BID  
Number 6736 OF**

CDL			e. The platform shall measure a minimum of 34" wide by 51" long.
CDL			f. The platform shall be equipped with a hydraulic powered automatic outboard roll stop.
CDL			g. The platform shall rise and descend smoothly while bearing a maximum load of 800 lbs. in ambient temperatures of -25° to +115° F.
CDL			h. The entire lift electrical system shall be protected by a master circuit breaker.
CDL			i. Maximum operating current shall not exceed 180 amps.
CDL			j. Lift control switches shall be clearly labeled and housed in a hand-held, weatherproof switch box.
CDL			k. The switch box shall provide remote control of all lift functions.
CDL			l. The switch box shall be connected to the end of a coiled, retractable electrical cable.
CDL			m. There shall be two (2) mounting areas to secure the handheld control box when vehicle is not in use:
CDL			i. One (1) to provide access from within the vehicle.
CDL			ii. One (1) to provide access from outside the vehicle when lift doors are open.
CDL			n. All lift controls shall be clearly labeled.
CDL			o. Wheelchair lift and installation shall comply with <b>FMVSS 403</b> and <b>404</b> .
			<b>3. Wheelchair Lift Mount:</b>
CDL			a. Shall be mounted to provide dual access by both ambulatory and non-ambulatory passengers through the same door.
CDL			b. The mounting system shall be the Fenton Mobility Products Shift-N-Step.
CDL			c. The mounting system must comply with <b>FMVSS 404</b> in fully retracted and fully extended positions.
			<b>4. Wheelchair Securement:</b>
CDL			a. Each wheelchair position shall be equipped with an auto-tensioning, auto locking retractor style restraint system that allows for final tightening of the securement.
CDL			b. The restraint must be quick attach and quick release.
CDL			c. The securement system must meet the requirements of <b>FMVSS DOT 49 CFR Part 38</b> and <b>WC 18</b> .
CDL			d. The securement system shall be installed according to the manufacturer's specifications.
CDL			e. The securement system items should be produced by Q'STRAIT/Sure-Lok.
CDL			f. Securement system shall be Kit No. AL812S-4C-7 and contain the following:
CDL			i. Four (4) - AL800855S auto-tensioning retractors with L track fitting, tightening knobs, stud fitting and J hook.
CDL			ii. One (1) - AL700868-4 occupant restraint buckle connector assembly with stud fitting.
CDL			iii. One (1) - AL700771 fixed-point mount occupant restraint retractor with height adjuster and stud fitting.
CDL			g. 8705 Web Cutter.
CDL			h. FE200750 Quick Strap – four (4) per position.
CDL			i. FE2001145 Storage Container for the wheelchair tie downs shall be anchored to the side wall and the bottom of the bag is to be a minimum of 15" above the floor.
		CDL	j. SLCE03 Training Program CD (one (1) per vehicle).

**INVITATION TO BID  
Number 6736 OF**

<i>CDL</i>			k. 96" long AL700842 Sure-Lok Integrated Lap Belt to be provided.
		<i>CDL</i>	l. An L-Track must be installed along the length of each side wall above the window to accommodate the adjustment of the occupant restraint.
<i>CDL</i>			5. At least one (1) grab handle each shall be provided on the sides of the driver door and both passenger side doors.

**NOTES/COMMENTS:** *Wheelchair Lift - Braun NCL9191B-2*  
*4-J. Training is available at Qstrain.com The CD Is no longer available*  
*4-1.5 L-Track Pods placed above windows to allow restraint flexibility*

**R. ACCEPTABLE BRANDS**

YES	NO	NO & PROVIDE ALTERNATIVE	
<i>CDL</i>			1. Products proposed must be the brand AND model numbers as specified on each line of the Solicitation Document. The State will not be accepting alternatives to the brands specified 2023 or Current Production Year Ford Transit XLT.
<i>CDL</i>			2. Equipment proposed shall be the latest current models in production as of the date of the solicitation and be of proven performance and under standard design, complete as regularly advertised and marketed and shall be delivered complete with all necessary parts, specified accessories, tools, and special features, whether or not they may be specifically mentioned below.
<i>CDL</i>			3. Used, demonstrator, prototype, or discontinued equipment is not acceptable. Complete specifications, manufacturer's descriptive literature and/or advertising data sheets with cuts or photographs may be required prior to an award and should be included with the bid on the IDENTICAL equipment proposed.
<i>CDL</i>			4. Literature should be complete and the latest published. Any information necessary to show compliance with these specifications not given on the manufacturer's descriptive literature and/or advertising data sheets should be supplied in writing on or attached to the bid document. 2023 or Current Production Year Ford Transit XLT bid must meet or exceed the following requirements.

**NOTES/COMMENTS:**

**S. ANNUAL USAGE, ESTIMATED**

YES	NO	NO & PROVIDE ALTERNATIVE	
<i>CDL</i>			1. Annual usage figures provided are estimates and are not to be construed as either a minimum or maximum purchase quantity.
<i>CDL</i>			2. The orders shall be for the actual quantities of each item ordered by or for any agency during the life of the contract.
<i>CDL</i>			3. Vendor shall not impose minimum order requirements.
<i>CDL</i>			4. Annual Estimated Usage is 50 units.

**NOTES/COMMENTS:**



**INVITATION TO BID  
Number 6736 OF**

**T. USAGE REPORT**

YES	NO	NO & PROVIDE ALTERNATIVE	
CDL			1. The Vendor shall, upon request, by the SPB, as determined by the State provide a usage report, of specified time period, of this contract by State agencies and political subdivisions. Information will include Agency name, item, and dollar amount. Information may be requested at any time.
NOTES/COMMENTS:			

**U. DELIVERY ARO**

YES	NO	NO & PROVIDE ALTERNATIVE	
CDL			1. Delivery desired within 160 days after receipt of order(s).
CDL			2. Quoted deliveries beyond 160 days ARO may be an award consideration.
NOTES/COMMENTS:			

**V. DELIVERY LOCATIONS / INSTRUCTIONS**

YES	NO	NO & PROVIDE ALTERNATIVE	
CDL			1. All vehicles shall be delivered FOB Destination to the location on the purchase order in accordance with the Delivery Schedule shown on the purchase order.
			2. <b>NDOT DELIVERY LOCATION/INSTRUCTIONS:</b>
CDL			a. <b>All orders placed by NDOT should be delivered to:</b> Nebraska Department of Transportation 5001 S 14 <sup>th</sup> Street Lincoln, NE.68502
CDL			b. Deliveries shall be made between 8:00 a.m. and 3:00 p.m. Central, Monday through Friday, except Saturdays, Sundays, and all State and Federally observed holidays.
CDL			c. All NDOT deliveries must be scheduled with the Agency Representative.at least two (2) working days before the vehicle(s) is delivered.
CDL			d. A maximum of five (5) vehicles may be delivered at one time. No other vehicles may be delivered until previous vehicles have passed inspection.
CDL			3. <b>All order deliveries for <u>Agencies other than NDOT</u> must be scheduled with the ordering Agency Representative.</b>
CDL			4. Vehicles are to be road ready, fully equipped, serviced, and washed with the equivalent of a ½ tank of gasoline upon delivery to final destination.
			5. <b>Odometer Mileage:</b>
CDL			a. Vehicles purchased within a 200-mile radius of Lincoln should show less than 200 miles on the odometer when delivered.
CDL			b. Vehicles purchased outside the 200-mile radius of Lincoln should show less than 450 miles on the odometer when delivered.
CDL			6. The original manufacturer's statement of origin or original title, a service authorization card, and a properly executed service and warranty policy shall accompany each vehicle when delivered.
CDL			7. Vehicles will not be accepted if all paper work is not with the vehicle at the time of delivery.
NOTES/COMMENTS:			

**INVITATION TO BID  
Number 6736 OF**

**W. ORDERS**

YES	NO	NO & PROVIDE ALTERNATIVE	
CDL			1. Orders will be placed either by, phone, e-mail, or Internet (if available and not to the exclusion of the other methods).
CDL			2. The Vendor shall provide the order number to the Agency Representative within five (5) business days after the Purchase Order has been received. The Vendor shall email, fax, or mail this information to the purchasing Agency.
CDL			3. Items not listed on the contract, but are required for the ordering Agency's business needs, may be added to the purchase order to complete the purchase of the vehicle. Please contact the awarded bidder for pricing.
CDL			4. Purchase orders issued from the resulting contract(s) may specify prospective delivery dates due to Agency operational needs and budget.
CDL			5. Upon acceptance of the purchase order, the Vendor agrees to abide by any such prospective delivery date.
CDL			6. All orders must reference a purchase order number.
CDL			7. The purchase order number must be referenced on the packing slip.

**NOTES/COMMENTS:**

**X. INVOICES**

YES	NO	NO & PROVIDE ALTERNATIVE	
CDL			1. Invoices shall include, at the least, Make & Model of Vehicle, the VIN, key number and State of Nebraska purchase order number.
CDL			2. The purchase order number must be referenced on the invoice.
CDL			3. Invoices are to be sent to the "Invoice to" address on the purchase order.
CDL			4. Invoices for payments must be submitted by the Vendor to the agency requesting the services with sufficient detail to support payment.
CDL			5. The Terms and Conditions included in the Vendor's invoice shall be deemed to be solely for the convenience of the parties. No terms or conditions of any such invoice shall be binding upon the State, and no action by the State, including without limitation the payment of any such invoice in whole or in part, shall be construed as binding or estopping the State with respect to any such term or condition, unless the invoice term or condition has been previously agreed to by the State as an amendment to the contract.

**NOTES/COMMENTS:**

**Y. QUALITY**

YES	NO	NO & PROVIDE ALTERNATIVE	
CDL			1. Product quality must meet specifications and be consistent for the term of the contract. All materials must be of first quality, under standard production by the manufacturer and be of standard design, complete as regularly advertised and marketed and be of proven performance.
CDL			2. A guarantee of satisfactory performance by the vendor and meeting delivery dates are an integral part of the purchase contract resulting from this bid invitation.

**INVITATION TO BID  
Number 6736 OF**

<i>CDL</i>			3. Products are to be fully guaranteed and may be returned for full credit or replacement (at the State's option) for any reason during the initial warranty period with no additional charges for shipping or restocking.
<b>NOTES/COMMENTS:</b>			

**Z. AUTHORIZED DEALER**

YES	NO	NO & PROVIDE ALTERNATIVE	
<i>CDL</i>			1. To the extent required by the manufacturer, the Vendor shall be an authorized dealer.
<i>CDL</i>			2. Vendor may be required to substantiate that he/she is an authorized dealer.
<i>CDL</i>			3. Proof, if required, must be submitted to SPB within three (3) business days of the request and prior to the award of any contract.
<b>NOTES/COMMENTS:</b>			

**AA. WARRANTY**

YES	NO	NO & PROVIDE ALTERNATIVE	
<i>CDL</i>			1. The terms of the original manufacturer's standard warranty shall apply to all equipment acquired from this solicitation for the entire warranty period.
<i>CDL</i>			2. The Vendor warrants for a period of one (1) year from the date of Acceptance that:
<i>CDL</i>			a. The products perform according to all specific claims that the Vendor made in its response to the solicitation;
<i>CDL</i>			b. The product is suitable for the ordinary purposes for which such Product is used;
<i>CDL</i>			c. The product is suitable for any special purposes identified in the solicitation or for which the State has relied on the Vendor's skill or judgment;
<i>CDL</i>			d. The product is designed and manufactured in a commercially reasonable manner; and
<i>CDL</i>			e. The product is free of defects.
<i>CDL</i>			3. Upon breach of the warranty, the Vendor will repair or replace (at no charge to the State) the Product whose nonconformance is discovered and made known to the Vendor.
<i>CDL</i>			4. If the repaired and/or replaced Product proves to be inadequate, or fails of its essential purpose, the Vendor will refund the full amount of any payments that have been made.
<i>CDL</i>			5. The rights and remedies of the parties under this warranty are in addition to any other rights and remedies of the parties provided by law or equity, including, without limitation actual damages, and, as applicable and awarded under the law, to a prevailing party, reasonable attorneys' fees, and costs.
<i>CDL</i>			6. Complete warranty and after-sales service must be available in Nebraska for the vehicle and all installed subsystems, including air conditioning systems, wheelchair lifts, etc.
<b>NOTES/COMMENTS:</b>			

---

2023 Transit-350 Passenger AWD High Roof HD Ext. Van 148" WB DRW XLT (U5X)

Price Level: 315

---



**Client Proposal**

Prepared by:

Connor Rosselot

Office: 216-313-8392

Email: [crosselot@valley2.com](mailto:crosselot@valley2.com)

Date: 12/09/2022



Valley Ford Truck, Inc. | 5715 Canal Road, Cleveland, Ohio, 441253494

Office: 216-524-2400 | Fax: 216-524-8527



Prepared by: Connor Rosselot  
12/09/2022

Valley Ford Truck, Inc. | 5715 Canal Road Cleveland Ohio | 441253494

## 2023 Transit-350 Passenger AWD High Roof HD Ext. Van 148" WB DRW XLT (U5X)

Price Level: 315

### As Configured Vehicle

Code	Description
<b>Base Vehicle</b>	
U5X	Base Vehicle Price (U5X)
<b>Packages</b>	
302A	<p><b>Order Code 302A</b></p> <p><i>Includes:</i></p> <ul style="list-style-type: none"> <li>- Engine: 3.5L EcoBoost V6 <i>Includes auto start-stop technology.</i></li> <li>- Transmission: 10-Spd Automatic w/OD &amp; SelectShift <i>Includes auxiliary transmission oil cooler.</i></li> <li>- 3.73 Limited-Slip Axle Ratio</li> <li>- GVWR: 10,360 lbs</li> <li>- Tires: 205/75R16C 113/111 AS BSW</li> <li>- Wheels: 16" Heavy Duty Silver Steel <i>Includes silver hubcaps with exposed lug nuts. The center ornament only comes on the front wheels, and not on the rear wheels.</i></li> <li>- Dark Palazzo Gray Cloth Bucket Seats <i>Includes 2-way manual driver seat with lumbar, 2-way manual passenger seat and driver and passenger armrest.</i></li> <li>- Cloth Front Bucket Seats</li> <li>- Radio: AM/FM Stereo w/SYNC 4 &amp; Nav <i>Includes 12" display, Bluetooth, dual USB ports, embedded voice recognition, connected navigation (90 day trial) and 8 speakers (4 front/4 rear).</i></li> <li>- Electronic Air Temperature Control</li> </ul>
<b>Powertrain</b>	
99G	<p><b>Engine: 3.5L EcoBoost V6</b></p> <p><i>Includes auto start-stop technology.</i></p>
44U	<p><b>Transmission: 10-Spd Automatic w/OD &amp; SelectShift</b></p> <p><i>Includes auxiliary transmission oil cooler.</i></p>
STDGV	GVWR: 10,360 lbs
<b>Wheels &amp; Tires</b>	
STDTR	Tires: 205/75R16C 113/111 AS BSW
STDWL	<p><b>Wheels: 16" Heavy Duty Silver Steel</b></p> <p><i>Includes silver hubcaps with exposed lug nuts. The center ornament only comes on the front wheels, and not on the rear wheels.</i></p>
<b>Seats &amp; Seat Trim</b>	
21L	<p><b>Dark Palazzo Gray Cloth Bucket Seats</b></p> <p><i>Includes 2-way manual driver seat with lumbar, 2-way manual passenger seat and driver and passenger armrest.</i></p>

Prices and content availability as shown are subject to change and should be treated as estimates only. Actual base vehicle, package and option pricing may vary from this estimate because of special local pricing, availability or pricing adjustments not reflected in the dealer's computer system. See salesperson for the most current information.



Prepared by: Connor Rosselot  
12/09/2022

Valley Ford Truck, Inc. | 5715 Canal Road Cleveland Ohio | 441253494

**2023 Transit-350 Passenger AWD High Roof HD Ext. Van 148" WB DRW XLT (U5X)**

Price Level: 315

**As Configured Vehicle (cont'd)**

<b>Code</b>	<b>Description</b>
C	Cloth Front Bucket Seats
96K	2-Passenger Seats w/Add. Rear Seat Attachment Points <i>13 rear seats are removed, but seat attachment points are still present.</i>

**Other Options**

PAINT	Monotone Paint Application
148WB	148" Wheelbase
19X	Auto Start-Stop Delete
18P	50/50 Hinged Rear Door w/253-Degree Opening
66D	Front Overhead Shelf
53K	Modified Vehicle Wiring System <i>Includes modified vehicle connections for customized wiring harness provisions.</i>
58B	Radio: AM/FM Stereo w/SYNC 4 & Nav <i>Includes 12" display, Bluetooth, dual USB ports, embedded voice recognition, connected navigation (90 day trial) and 8 speakers (4 front/4 rear).</i>  <i>Includes:</i> <i>- Electronic Air Temperature Control</i>
63E	Dual AGM Batteries (70 Amp-hr Each)
47E	Builder's Prep Package <i>Deletes rear floor covering, rear-seats and restraints and rear-seat rails and fasteners.</i>  <i>Includes:</i> <i>- Dual AGM Batteries (70 Amp-hr Each)</i> <i>- Modified Vehicle Wiring System</i> <i>Includes modified vehicle connections for customized wiring harness provisions.</i> <i>- Front Only Carpet Floor Covering</i> <i>Deletes all rear floor covering.</i> <i>- 2-Passenger Seats w/Add. Rear Seat Attachment Points</i> <i>13 rear seats are removed, but seat attachment points are still present.</i>

**Fleet Options**

942	Daytime Running Lights <b>Requires valid FIN or dealer code.</b> <i>Provides enhanced vehicle visibility during daylight conditions.</i>
-----	--

Prices and content availability as shown are subject to change and should be treated as estimates only. Actual base vehicle, package and option pricing may vary from this estimate because of special local pricing, availability or pricing adjustments not reflected in the dealer's computer system. See salesperson for the most current information.



Prepared by: Connor Rosselot  
12/09/2022

Valley Ford Truck, Inc. | 5715 Canal Road Cleveland Ohio | 441253494

2023 Transit-350 Passenger AWD High Roof HD Ext. Van 148" WB DRW XLT (U5X)

Price Level: 315

As Configured Vehicle (cont'd)

Code	Description
WARANT	<p>Fleet Customer Powertrain Limited Warranty</p> <p>Requires valid FIN code.</p> <p><i>Ford is increasing the 5-year 60,000-mile limited powertrain warranty to 5-years, 100,000 miles. Only Fleet purchasers with a valid Fleet Identification Number (FIN code) will receive the extended warranty. When the sale is entered into the sales reporting system with a sales type fleet along with a valid FIN code, the warranty extension will automatically be added to the vehicle. The extension will stay with the vehicle even if it is subsequently sold to a non-fleet customer before the expiration. This extension applies to both gas and diesel powertrains. Dealers can check for the warranty extension on eligible fleet vehicles in OASIS. Please refer to the Warranty and Policy Manual section 3.13.00 Gas Engine Commercial Warranty. This change will also be reflected in the printed Warranty Guided distributed with the purchase of every new vehicle.</i></p>
<b>Emissions</b>	
425	50-State Emissions System
<b>Exterior Color</b>	
YZ_01	Oxford White
<b>Interior Color</b>	
CK_01	Dark Palazzo Gray w/Cloth Front Bucket Seats

Prices and content availability as shown are subject to change and should be treated as estimates only. Actual base vehicle, package and option pricing may vary from this estimate because of special local pricing, availability or pricing adjustments not reflected in the dealer's computer system. See salesperson for the most current information.



Prepared by: Connor Rosselot

12/09/2022

Valley Ford Truck, Inc. | 5715 Canal Road Cleveland Ohio | 441253494

## 2023 Transit-350 Passenger AWD High Roof HD Ext. Van 148" WB DRW XLT (U5X)

Price Level: 315

### Selected Equip & Specs

#### Dimensions

- Conventional Capacity: 3,400 lbs.
- Vehicle body length: 264"
- Vehicle body height: 108"
- Side door opening width: 51"
- Rear door opening width: 60"
- Wheelbase: 148"
- Rear track: 69"
- Front bumper to front axle: 40"
- Rear brake diameter: 12.1"
- Max interior cargo volume: 425 cu.ft.
- Leg room first-row: 41.3"
- Hip room first-row: 60.7"
- GCWR: 11,200 lbs.
- Vehicle body width: 81"
- Side door opening height: 63"
- Rear door opening height: 72"
- \* **Rear door opening angle: 253**
- Front track: 68"
- Vehicle turning radius: 24'
- Front brake diameter: 12.1"
- Interior cargo volume: 100 cu.ft.
- Headroom first-row: 56.6"
- Shoulder room first-row: 67.9"

#### Powertrain

- EcoBoost 3.5L V-6 gasoline direct injection, DOHC, variable valve control, twin turbo, engine with 310HP
- Spark ignition system
- Torque: 400 lb.-ft. @2500 RPM
- Auto stop-start engine
- Automatic full-time AWD
- Recommended fuel: regular unleaded
- Mechanical limited slip differential
- Permanent locking hub control
- Engine cylinders: V-6
- Horsepower: 310 HP@5000 RPM
- Radiator
- 10-speed automatic
- All-wheel drive
- Capless fuel filler
- All-speed ABS and driveline traction control

#### Fuel Economy and Emissions

- Gasoline secondary fuel type
- ULEV II emissions

#### Suspension and Handling

- Standard ride suspension
- Heavy-duty rear shock absorbers
- Gas-pressurized front shock absorbers

#### Driveability

- 4-wheel disc brakes
- 4-wheel antilock (ABS) brakes
- Ford Co-Pilot360 - Post Collision Braking automatic post-collision braking system
- Hill start assist
- Strut front suspension
- Front coil springs
- Leaf spring rear suspension
- Front ventilated disc brakes
- Four channel ABS brakes
- Brake assist system
- Independent front suspension
- Front anti-roll bar
- Rigid axle rear suspension
- Electric power-assist steering system

Prices and content availability as shown are subject to change and should be treated as estimates only. Actual base vehicle, package and option pricing may vary from this estimate because of special local pricing, availability or pricing adjustments not reflected in the dealer's computer system. See salesperson for the most current information.





Prepared by: Connor Rosselot  
12/09/2022

Valley Ford Truck, Inc. | 5715 Canal Road Cleveland Ohio | 441253494

## 2023 Transit-350 Passenger AWD High Roof HD Ext. Van 148" WB DRW XLT (U5X)

Price Level: 315

### Selected Equip & Specs (cont'd)

- Rack-pinion steering

- 2-wheel steering system

#### Body Exterior

- 3 doors
- Monotone paint
- Black wheel well trim
- Black windshield trim
- Body-coloured front bumper
- Rear tow hook
- Black door mirrors
- Turn signal indicator in door mirrors
- Split swing-out rear cargo door
- 16 x 6-inch front and dual rear silver steel wheels

- Clearcoat paint
- Black bodyside cladding
- Black side window trim
- Black door handles
- Black rear bumper
- Chrome grille
- Standard style side mirrors
- Sliding right rear passenger door
- LT205/75RS16 AS BSW front and rear tires

#### Convenience

- Power door locks with 2 stage unlocking
- All-in-one remote fob and ignition key
- Power tailgate/rear door lock
- Day/Night rearview mirror
- Full floor console
- Rear window defroster
- Locking glove box
- Rear beverage holders
- Rear door bins
- PRND in IP
- Over the air updates

- Keyfob activated door locks
- Auto-locking doors
- Cruise control with steering wheel mounted controls
- Power first-row windows
- Driver foot rest
- Fixed rear windshield
- Front beverage holders
- Driver and passenger door bins
- Instrument panel bin
- Trip computer

#### Comfort

- Automatic climate control
- Cloth headliner material
- \* **Front carpet floor covering**
- Carpet front floor mats
- Cloth rear seat upholstery
- Manual telescopic steering wheel

- Rear under seat climate control ducts
- Full headliner coverage
- \* **Front floor coverage**
- Cloth rear seat upholstery
- Manual tilting steering wheel
- Urethane steering wheel

#### Seats and Trim

- \* **Seating capacity: 2**
- Driver seat with 4-way directional controls
- Height adjustable front seat head restraints
- Driver seat armrest
- Manual reclining driver seat

- Bucket front seats
- Front passenger seat with 4-way directional controls
- Manual front seat head restraint control
- Front passenger seat armrest
- Manual driver seat fore/aft control

Prices and content availability as shown are subject to change and should be treated as estimates only. Actual base vehicle, package and option pricing may vary from this estimate because of special local pricing, availability or pricing adjustments not reflected in the dealer's computer system. See salesperson for the most current information.



Prepared by: Connor Rosselot

12/09/2022

Valley Ford Truck, Inc. | 5715 Canal Road Cleveland Ohio | 441253494

## 2023 Transit-350 Passenger AWD High Roof HD Ext. Van 148" WB DRW XLT (U5X)

Price Level: 315

### Selected Equip & Specs (cont'd)

- Manual reclining passenger seat
- Manual driver seat lumbar
- Third-row outboard-only seat mounted armrests
- Manual passenger seat fore/aft control
- Cloth front seat upholstery
- Fourth-row outboard-only seat mounted armrests

### Entertainment Features

- 1 total number of 1st row displays
- Primary monitor touchscreen
- Seek scan
- Speakers number: 8
- Steering wheel mounted audio controls
- Wireless audio streaming
- 12 inch primary LCD display
- AM/FM stereo radio
- SYNC 4 external memory control
- Standard grade speakers
- SYNC 4 with Enhanced Voice Recognition voice activated audio controls
- Fixed audio antenna

### Lighting, Visibility and Instrumentation

- Metal-look instrument panel insert
- Trip odometer
- Telematics Essentials vehicle systems monitor
- Engine/electric motor temperature gauge
- Projector beam headlights
- Ford Co-Pilot360 - Autolamp auto on/off headlight control
- Delay-off headlights
- Variable intermittent front windshield wipers
- Illuminated entry
- \* **Daytime running lights**
- Cab clearance lights
- Fade interior courtesy lights
- Analog instrumentation display
- In-radio display clock
- Tachometer
- Light tinted windows
- High-intensity discharge low and high beam headlights
- Multiple enclosed headlights
- Ford Co-Pilot360 - Auto High Beam auto high-beam headlights
- Front reading lights
- Variable instrument panel light
- Front fog lights
- High mounted center stop light

### Technology and Telematics

- SYNC 4 Connected Navigation integrated navigation system with voice activation
- Bluetooth handsfree wireless device connectivity
- FordPass Connect 4G mobile hotspot internet access
- Vehicle integrated emergency SOS system
- SYNC 4 AppLink incl. Apple CarPlay and Android Auto smart device app link
- 5 USB ports

### Safety and Security

- Driver front impact airbag
- \* **Curtain first-row overhead airbags**
- Seat mounted side impact front passenger airbag
- Seat mounted side impact driver airbag
- Passenger front impact airbag
- Airbag occupancy sensor

Prices and content availability as shown are subject to change and should be treated as estimates only. Actual base vehicle, package and option pricing may vary from this estimate because of special local pricing, availability or pricing adjustments not reflected in the dealer's computer system. See salesperson for the most current information.



Prepared by: Connor Rosselot

12/09/2022

Valley Ford Truck, Inc. | 5715 Canal Road Cleveland Ohio | 441253494

## 2023 Transit-350 Passenger AWD High Roof HD Ext. Van 148" WB DRW XLT (U5X)

Price Level: 315

### Selected Equip & Specs (cont'd)

- 6 airbags
- Front seatbelt pretensioners
- SecuriLock immobilizer
- Ford Co-Pilot360 - Lane-Keeping System
- Ford Co-Pilot360 - Pre-Collision Assist with Automatic Emergency Braking (AEB) forward collision mitigation
- Ford Co-Pilot360 - Driver Alert
- Ford Co-Pilot360 w/Side Wind Stabilization electronic stability control system with anti-roll
- Front height adjustable seatbelts
- 2 seatbelt pre-tensioners
- Remote panic alarm
- Ford Co-Pilot360 - BLIS with Trailer Tow Coverage active blind spot system
- Ford Co-Pilot360 - Cross-Traffic Alert collision warning
- High Resolution Digital Camera rear mounted camera
- Forward and Reverse Sensing System front and rear parking sensors

### Dimensions

#### General Weights

Curb weight	7,175 lbs.	Rear curb weight	3,822 lbs.
GVWR	10,360 lbs.	Payload	3,184 lbs.

#### Trailer Weights

Conventional capacity	3,400 lbs.	GCWR	11,200 lbs.
-----------------------	------------	------	-------------

#### Front Weights

Front curb weight	3,353 lbs.	GAWR front	4,630 lbs.
-------------------	------------	------------	------------

#### Rear Weights

GAWR rear	6,725 lbs.
-----------	------------

#### Off Road

Min ground clearance	6.0"	Loading floor height	27.8"
----------------------	------	----------------------	-------

#### Exterior Measurements

Vehicle body length	264"	Vehicle body width	81"
Vehicle body height	108"	Rear door opening height	72"
Rear door opening width	60"	<b>* Rear door opening angle</b>	<b>253</b>
Wheelbase	148"	Front brake diameter	12.1"
Rear brake diameter	12.1"	Side door opening height	63"
Side door opening width	51"	Front track	68"
Rear track	69"	Vehicle turning radius	24'
Front bumper to front axle	40"		

#### Interior Measurements

Interior cargo volume	100 cu.ft.	Max interior cargo volume	425 cu.ft.
Interior cargo area height	77"	Interior cargo length	170"
Interior cargo area min width	45"	Interior cargo area max width	70"
Length to rear seat	136"	Length to 3rd row seat	105"

Prices and content availability as shown are subject to change and should be treated as estimates only. Actual base vehicle, package and option pricing may vary from this estimate because of special local pricing, availability or pricing adjustments not reflected in the dealer's computer system. See salesperson for the most current information.



Prepared by: Connor Rosselot

12/09/2022

Valley Ford Truck, Inc. | 5715 Canal Road Cleveland Ohio | 441253494

## 2023 Transit-350 Passenger AWD High Roof HD Ext. Van 148" WB DRW XLT (U5X)

Price Level: 315

### Selected Equip & Specs (cont'd)

#### Headroom

Headroom first-row ..... 56.6"

#### Legroom

Leg room first-row ..... 41.3"

#### Shoulder Room

Shoulder room first-row ..... 67.9"

#### Hip Room

Hip room first-row ..... 60.7"

### Powertrain

#### Engine

Engine ..... EcoBoost 3.5L V-6 gasoline direct injection, DOHC, variable valve control, twin turbo, engine with 310HP

Engine cylinders ..... V-6

Ignition ..... Spark ignition system

Engine block material ..... Aluminum engine block

Valves per cylinder ..... 4

Engine location ..... Front mounted engine

Engine mounting direction ..... Longitudinal mounted engine

Cylinder head material ..... Aluminum cylinder head

#### Engine Specs

Displacement ..... 3.5L

Bore ..... 3.64"

Compression ratio ..... 10.0

cc ..... 213.4 cu.in.

Stroke ..... 3.41"

SAEJ1349 ..... AUG2004 compliant

#### Engine Power

Horsepower ..... 310 HP@5000 RPM

Torque ..... 400 lb.-ft. @2500 RPM

#### Alternator

Alternator amps ..... 250A

Alternator type ..... Heavy-duty alternator

#### Battery

Battery amps ..... 70Ah

\* **Battery type** ..... **Dual lead acid battery**

Battery run down protection ..... Battery run down protection

#### Engine Extras

Radiator ..... Radiator

Start-stop engine ..... Auto stop-start engine

#### Transmission

Transmission ..... 10-speed automatic

Transmission electronic control ..... Transmission electronic control

Overdrive transmission ..... Overdrive transmission

Lock-up transmission ..... Lock-up transmission

First gear ratio ..... 4.689

Second gear ratio ..... 2.985

Prices and content availability as shown are subject to change and should be treated as estimates only. Actual base vehicle, package and option pricing may vary from this estimate because of special local pricing, availability or pricing adjustments not reflected in the dealer's computer system. See salesperson for the most current information.



Prepared by: Connor Rosselot

12/09/2022

Valley Ford Truck, Inc. | 5715 Canal Road Cleveland Ohio | 441253494

## 2023 Transit-350 Passenger AWD High Roof HD Ext. Van 148" WB DRW XLT (U5X)

Price Level: 315

### Selected Equip & Specs (cont'd)

Third gear ratio .....	2.146	Fourth gear ratio .....	1.769
Fifth gear ratio .....	1.52	Sixth gear ratio .....	1.275
Reverse gear ratio .....	4.866	Seventh gear ratio .....	1
Eighth gear ratio .....	0.854	Ninth gear ratio .....	0.689
Tenth gear ratio .....	0.636	Sequential shift control .....	SelectShift Sequential shift control

Transmission oil cooler... Transmission oil cooler

#### Drive Type

4WD type ..... Automatic full-time AWD      Drive type ..... All-wheel drive

#### Drivetrain

Axle ratio .....

.....	3.73
-------	------

#### Exhaust

Tailpipe ..... Stainless steel single exhaust

#### Fuel

Fuel type ..... regular unleaded

#### Fuel Tank

Capless fuel filler ..... Capless fuel filler      Fuel tank capacity ..... 25.10 gal.

#### Drive Feature

Limited slip differential ..... Mechanical limited slip differential      Traction control ..... All-speed ABS and driveline traction control

Locking hub control ..... Permanent locking hub control

#### Provisions

\* Provisions ..... Van conversion package provisions

### Fuel Economy and Emissions

#### Fuel Economy

Secondary fuel type ..... Gasoline secondary fuel type

#### Emissions

Emissions ..... ULEV II emissions      Emissions tiers ..... Tier 2 Bin 5 emissions

### Suspension and Handling

#### Suspension

Suspension ..... Standard ride suspension      Front shock absorbers ..... Gas-pressurized front shock absorbers

Prices and content availability as shown are subject to change and should be treated as estimates only. Actual base vehicle, package and option pricing may vary from this estimate because of special local pricing, availability or pricing adjustments not reflected in the dealer's computer system. See salesperson for the most current information.



Prepared by: Connor Rosselot

12/09/2022

Valley Ford Truck, Inc. | 5715 Canal Road Cleveland Ohio | 441253494

## 2023 Transit-350 Passenger AWD High Roof HD Ext. Van 148" WB DRW XLT (U5X)

Price Level: 315

### Selected Equip & Specs (cont'd)

Rear shock absorbers ..... Heavy-duty rear shock absorbers

#### Driveability

##### Brakes

Brake type ..... 4-wheel disc brakes  
ABS brakes ..... Four channel ABS brakes  
Post collision braking system ..... Ford Co-Pilot360 - Post Collision Braking automatic post-collision braking system

Ventilated brakes ..... Front ventilated disc brakes  
ABS brakes ..... 4-wheel antilock (ABS) brakes

##### Brake Assistance

Hill start assist ..... Hill start assist

Brake assist system ..... Brake assist system

##### Front Suspension

Anti-roll bar front ..... Front anti-roll bar

Suspension ride type front ..... Independent front suspension

Suspension type front ..... Strut front suspension

##### Front Spring

Regular front springs ..... Regular front springs

Springs front ..... Front coil springs

##### Rear Spring

Springs rear ..... Rear leaf springs

Rear springs ..... Regular grade rear springs

##### Rear Suspension

Suspension type rear ..... Leaf spring rear suspension

Suspension ride type rear ..... Rigid axle rear suspension

##### Steering

Steering Electric power-assist steering system  
Steering type number of wheels ..... 2-wheel steering system

Steering type ..... Rack-pinion steering

#### Exterior

##### Front Wheels

Front wheels diameter ..... 16"

Front wheels width ..... 6"

##### Rear Wheels

Rear wheels diameter ..... 16"

Rear wheels width ..... 6"

##### Front And Rear Wheels

Appearance ..... silver

Material ..... steel

##### Front Tires

Aspect ..... 75

Diameter ..... 16"

Prices and content availability as shown are subject to change and should be treated as estimates only. Actual base vehicle, package and option pricing may vary from this estimate because of special local pricing, availability or pricing adjustments not reflected in the dealer's computer system. See salesperson for the most current information.



Prepared by: Connor Rosselot

12/09/2022

Valley Ford Truck, Inc. | 5715 Canal Road Cleveland Ohio | 441253494

## 2023 Transit-350 Passenger AWD High Roof HD Ext. Van 148" WB DRW XLT (U5X)

Price Level: 315

### Selected Equip & Specs (cont'd)

Sidewalls .....	BSW	Speed .....	S
Tread .....	AS	Type .....	LT
Width .....	205mm		

#### Rear Tires

Aspect .....	75	Diameter .....	16"
Sidewalls .....	BSW	Speed .....	S
Tread .....	AS	Type .....	LT
Width .....	205mm		

### Body Exterior

#### Exterior Features

Number of doors ..... 3 doors

#### Body

Body panels ..... Fully galvanized steel body panels with side impact beams

#### Mirrors

Turn signal in door mirrors Turn signal indicator in door mirrors

#### Spare Tire

Spare tire .. Full-size spare tire with steel wheel Spare tire location ..... Crank-down spare tire

#### Tires

Front tires LT load rating ..... C Rear tires LT load rating ..... C

#### Wheels

Dual rear wheels ..... Dual rear wheels

### Convenience

#### Door Locks

Door locks ..... Power door locks with 2 stage unlocking Keyfob door locks .. Keyfob activated door locks

All-in-one key All-in-one remote fob and ignition key Auto door locks ..... Auto-locking doors

Tailgate control ..... Power tailgate/rear door lock

#### Cruise Control

Cruise control ..... Cruise control with steering wheel mounted controls

#### Rear View Mirror

Day/Night rearview mirror ..... Day/Night rearview mirror

Prices and content availability as shown are subject to change and should be treated as estimates only. Actual base vehicle, package and option pricing may vary from this estimate because of special local pricing, availability or pricing adjustments not reflected in the dealer's computer system. See salesperson for the most current information.



2023 Transit-350 Passenger AWD High Roof HD Ext. Van 148" WB DRW XLT (U5X)

Price Level: 315

## Selected Equip & Specs (cont'd)

### Exterior Mirrors

Door mirrors .....	Power door mirrors	Folding door mirrors .....	Power folding door mirrors
Heated door mirrors .....	Heated driver and passenger side door mirrors		

### Front Side Windows

First-row windows .....	Power first-row windows
-------------------------	-------------------------

### Floor Console

Floor console .....	Full floor console	Floor console storage .....	Floor console storage
---------------------	--------------------	-----------------------------	-----------------------

### Overhead Console

* Overhead console .....	<b>Full overhead console</b>	* Overhead console storage .....	<b>Overhead console storage</b>
--------------------------	------------------------------	----------------------------------	---------------------------------

### Driver Visor

Visor driver mirror .....	Driver visor mirror	Visor illuminated driver mirror .....	Illuminated driver visor mirror
---------------------------	---------------------	---------------------------------------	---------------------------------

### Passenger Visor

Visor passenger mirror .....	Passenger visor mirror	Visor illuminated passenger mirror .....	Illuminated passenger visor mirror
------------------------------	------------------------	--	------------------------------------

### Power Outlets

12V power outlets .....	2 12V power outlets
-------------------------	---------------------

### Cargo Features

Cargo tie downs .....	Cargo area tie downs
-----------------------	----------------------

### Pedals

Driver foot rest .....	Driver foot rest
------------------------	------------------

### Rear Windshield

Rear window defroster .....	Rear window defroster	Rear windshield .....	Fixed rear windshield
-----------------------------	-----------------------	-----------------------	-----------------------

### Storage

Door bins front .....	Driver and passenger door bins	Door bins rear .....	Rear door bins
Beverage holders .....	Front beverage holders	Beverage holders rear .....	Rear beverage holders
Glove box .....	Locking glove box	Instrument panel storage .....	Instrument panel bin

### Windows Feature

One-touch down window .....	Driver one-touch down window
-----------------------------	------------------------------

### Windows Rear Side

Second-row windows .....	Fixed second-row windows	Third-row windows .....	Fixed third-row windows
--------------------------	--------------------------	-------------------------	-------------------------





Prepared by: Connor Rosselot

12/09/2022

Valley Ford Truck, Inc. | 5715 Canal Road Cleveland Ohio | 441253494

## 2023 Transit-350 Passenger AWD High Roof HD Ext. Van 148" WB DRW XLT (U5X)

Price Level: 315

### Selected Equip & Specs (cont'd)

#### Miscellaneous

Trip computer .....	Trip computer	PRND in IP .....	PRND in IP
Over the air updates .....	Over the air updates		

### Comfort

#### Climate Control

Climate control .....	Automatic climate control	Rear under seat ducts .....	Rear under seat climate control ducts
-----------------------	---------------------------	-----------------------------	---------------------------------------

#### Headliner

Headliner material .....	Cloth headliner material	Headliner coverage .....	Full headliner coverage
--------------------------	--------------------------	--------------------------	-------------------------

#### Floor Trim

* Floor covering .....	<b>Front carpet floor covering</b>	* Floor coverage .....	<b>Front floor coverage</b>
Floor mats .....	Carpet front floor mats		

#### Second-Row Seat Trim

Rear seat upholstery .....	Cloth rear seat upholstery
----------------------------	----------------------------

#### Third-Row Seat Trim

Third-row seat upholstery .....	Cloth rear seat upholstery
---------------------------------	----------------------------

#### Steering Wheel

Steering wheel telescopic .....	Manual telescopic steering wheel	Steering wheel material .....	Urethane steering wheel
Steering wheel tilt .....	Manual tilting steering wheel		

### Seats and Trim

#### Seat Capacity

* Seating capacity .....	<b>2</b>
--------------------------	----------

#### Front Seats

Driver seat direction .....	Driver seat with 4-way directional controls	Driver seat fore/aft control .....	Manual driver seat fore/aft control
Passenger seat direction .....	Front passenger seat with 4-way directional controls	Split front seats .....	Bucket front seats
Reclining passenger seat .....	Manual reclining passenger seat	Passenger seat fore/aft control .....	Manual passenger seat fore/aft control
Front head restraints .....	Height adjustable front seat head restraints	Front head restraint control .....	Manual front seat head restraint control
Armrests front driver .....	Driver seat armrest	Armrests front passenger .....	Front passenger seat armrest
Reclining driver seat .....	Manual reclining driver seat		

Prices and content availability as shown are subject to change and should be treated as estimates only. Actual base vehicle, package and option pricing may vary from this estimate because of special local pricing, availability or pricing adjustments not reflected in the dealer's computer system. See salesperson for the most current information.



Prepared by: Connor Rosselot

12/09/2022

Valley Ford Truck, Inc. | 5715 Canal Road Cleveland Ohio | 441253494

## 2023 Transit-350 Passenger AWD High Roof HD Ext. Van 148" WB DRW XLT (U5X)

Price Level: 315

### Selected Equip & Specs (cont'd)

#### Rear Seats

\* **Armrests rear mounted** ... **Rear seat outboard-only mounted armrests**

#### Lumbar Seats

Driver lumbar ..... Manual driver seat lumbar

#### Front Seat Trim

Front seat upholstery Cloth front seat upholstery

Front seatback upholstery ..... Cloth front seatback upholstery

#### Third-Row Seats

Armrests third-row mounted ... Third-row outboard-only seat mounted armrests

#### Fourth-Row Seats

Armrests fourth-row mounted ..... Fourth-row outboard-only seat mounted armrests

#### Gearshifter Material

Gearshifter material ..... Urethane gear shifter material

### Entertainment Features

#### LCD Displays

Primary monitor touchscreen ..... Primary monitor touchscreen

Number of first-row LCD displays 1 total number of 1st row displays

LCD primary display size ..... 12 inch primary LCD display

#### Radio Features

External memory ..... SYNC 4 external memory control

Seek scan ..... Seek scan

#### Speakers

Speakers ..... Standard grade speakers

Speakers number ..... 8

#### Audio Features

Steering mounted audio control ..... Steering wheel mounted audio controls

Voice activated audio ..... SYNC 4 with Enhanced Voice Recognition voice activated audio controls

Wireless streaming ..... Wireless audio streaming

### Lighting, Visibility and Instrumentation

#### Instrument Panel Trim

Prices and content availability as shown are subject to change and should be treated as estimates only. Actual base vehicle, package and option pricing may vary from this estimate because of special local pricing, availability or pricing adjustments not reflected in the dealer's computer system. See salesperson for the most current information.



Prepared by: Connor Rosselot

12/09/2022

Valley Ford Truck, Inc. | 5715 Canal Road Cleveland Ohio | 441253494

## 2023 Transit-350 Passenger AWD High Roof HD Ext. Van 148" WB DRW XLT (U5X)

Price Level: 315

### Selected Equip & Specs (cont'd)

Panel insert Metal-look instrument panel insert

#### Instrumentation

Trip odometer ..... Trip odometer

Instrumentation display ... Analog instrumentation display

#### Instrumentation Displays

Systems monitor Telematics Essentials vehicle systems monitor

Clock ..... In-radio display clock

#### Instrumentation Gauges

Tachometer ..... Tachometer

Engine/electric motor temperature gauge ..... Engine/electric motor temperature gauge

#### Instrumentation Warnings

Engine temperature warning Engine temperature warning

Oil pressure warning ..... Oil pressure warning

Low fuel warning ..... Low fuel warning

Low washer fluid warning ..... Low washer fluid warning

Low brake fluid warning Low brake fluid warning

Battery charge warning ... Battery charge warning

Headlights on reminder Headlights on reminder

Key in vehicle warning ... Key in vehicle warning

Door ajar warning ..... Door ajar warning

Trunk warning ..... Rear cargo ajar warning

Service interval warning Service interval indicator

Low tire pressure warning ..... Low tire pressure warning

#### Glass

Tinted windows ..... Light tinted windows

#### Headlights

Headlights ... High-intensity discharge low and high beam headlights

Headlight type ..... Projector beam headlights

Auto headlights ... Ford Co-Pilot360 - Autolamp auto on/off headlight control

Multiple headlights Multiple enclosed headlights

Delay off headlights ..... Delay-off headlights

Auto high-beam headlights ... Ford Co-Pilot360 - Auto High Beam auto high-beam headlights

#### Front Windshield

Wipers ... Variable intermittent front windshield wipers

#### Windshield Wipers

Rain detecting wipers ..... Rain detecting wipers

#### Interior Lighting

Illuminated entry ..... Illuminated entry

Variable panel light ... Variable instrument panel light

Prices and content availability as shown are subject to change and should be treated as estimates only. Actual base vehicle, package and option pricing may vary from this estimate because of special local pricing, availability or pricing adjustments not reflected in the dealer's computer system. See salesperson for the most current information.



Prepared by: Connor Rosselot

12/09/2022

Valley Ford Truck, Inc. | 5715 Canal Road Cleveland Ohio | 441253494

## 2023 Transit-350 Passenger AWD High Roof HD Ext. Van 148" WB DRW XLT (U5X)

Price Level: 315

### Selected Equip & Specs (cont'd)

Front reading lights ..... Front reading lights

#### Lights

\* **Running lights** ..... **Daytime running lights**

Fog lights ..... Front fog lights

High mount stop light High mounted center stop light

Interior courtesy lights ..... Fade interior courtesy lights

Clearance lights ..... Cab clearance lights

### Technology and Telematics

#### Navigation

Integrated navigation ..... SYNC 4 Connected Navigation integrated navigation system with voice activation

#### Connectivity

Handsfree ..... Bluetooth handsfree wireless device connectivity

Emergency SOS Vehicle integrated emergency SOS system

Smart device integration ... SYNC 4 AppLink incl. Apple CarPlay and Android Auto smart device app link

#### Internet Access

Internet access ... FordPass Connect 4G mobile hotspot internet access

#### USB Ports

USB ports ..... 5 USB ports

### Safety and Security

#### Airbags

Front impact airbag driver ..... Driver front impact airbag

Front impact airbag passenger ..... Passenger front impact airbag

Front side impact airbag passenger Seat mounted side impact front passenger airbag

\* **Overhead airbags** **Curtain first-row overhead airbags**

Number of airbags ..... 6 airbags

Front side impact airbag driver Seat mounted side impact driver airbag

Occupancy sensor ..... Airbag occupancy sensor

#### Seatbelts

Height adjustable seatbelts ..... Front height adjustable seatbelts

Seatbelt pretensioners ..... Front seatbelt pretensioners

Prices and content availability as shown are subject to change and should be treated as estimates only. Actual base vehicle, package and option pricing may vary from this estimate because of special local pricing, availability or pricing adjustments not reflected in the dealer's computer system. See salesperson for the most current information.



Prepared by: Connor Rosselot  
12/09/2022

Valley Ford Truck, Inc. | 5715 Canal Road Cleveland Ohio | 441253494

---

## 2023 Transit-350 Passenger AWD High Roof HD Ext. Van 148" WB DRW XLT (U5X)

Price Level: 315

---

### Selected Equip & Specs (cont'd)

Seatbelt pretensioners number ..... 2 seatbelt pretensioners

#### *Security System*

Immobilizer ..... SecuriLock immobilizer

Remote panic alarm ..... Remote panic alarm

#### *Active Driving Assistance*

Lane departure ..... Ford Co-Pilot360 - Lane-Keeping System

Blind spot Ford Co-Pilot360 - BLIS with Trailer Tow Coverage active blind spot system

Forward collision warning Ford Co-Pilot360 - Pre-Collision Assist with Automatic Emergency Braking (AEB) forward collision mitigation

Rear collision warning Ford Co-Pilot360 - Cross-Traffic Alert collision warning

Driver attention monitor Ford Co-Pilot360 - Driver Alert

#### *Cameras*

Rear camera .. High Resolution Digital Camera rear mounted camera

#### *Traction Control*

Electronic stability control ..... Ford Co-Pilot360 w/Side Wind Stabilization electronic stability control system with anti-roll

#### *Parking Sensors*

Parking sensors Forward and Reverse Sensing System front and rear parking sensors



Prepared by: Connor Rosselot  
12/09/2022

Valley Ford Truck, Inc. | 5715 Canal Road Cleveland Ohio | 441253494

---

## 2023 Transit-350 Passenger AWD High Roof HD Ext. Van 148" WB DRW XLT (U5X)

Price Level: 315

---

### Vehicle Dimension and Performance Summary

Performance predictions in this report represent an estimate of vehicle performance based on standard operating conditions. Variations in customer equipment, load configuration, ambient conditions, and/or operator driving techniques can cause significant variations in vehicle performance. These values are not representative of results that may be shown in actual dynamometer tests. This report should therefore be used as a guide for comparative vehicle performance.

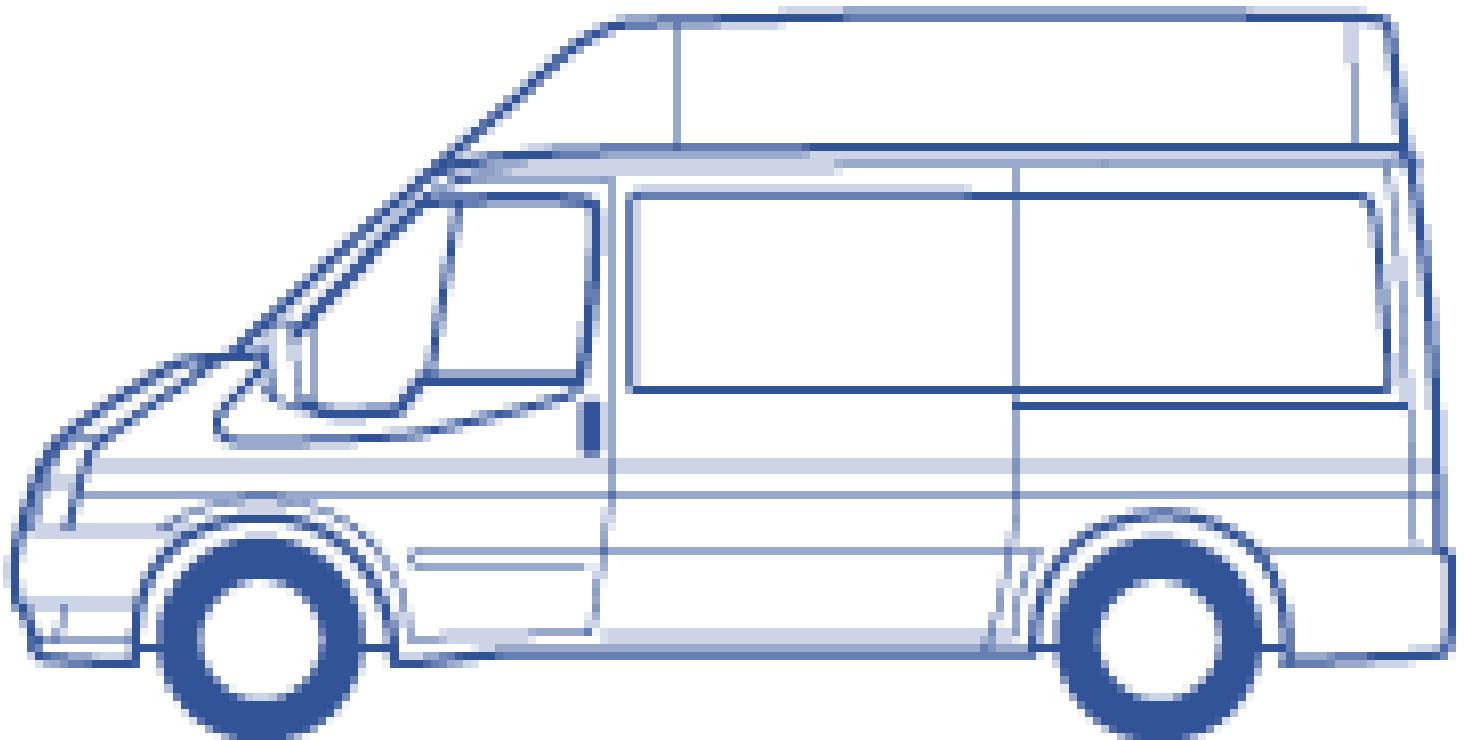

---

Prices and content availability as shown are subject to change and should be treated as estimates only. Actual base vehicle, package and option pricing may vary from this estimate because of special local pricing, availability or pricing adjustments not reflected in the dealer's computer system. See salesperson for the most current information.



Prepared by: Connor Rosselot  
12/09/2022

Valley Ford Truck, Inc. | 5715 Canal Road Cleveland Ohio | 441253494

---

2023 Transit-350 Passenger AWD High Roof HD Ext. Van 148" WB DRW XLT (U5X)

Price Level: 315

---

## Vehicle Dimension and Performance Summary (cont'd)

### *Light Duty*

GVWR ..... 10,360 lbs

GVW ..... Totals

---

1 Payload - (Added Equipment ) ..... 0 lbs

Occupants Weight ..... 2,250 lbs

Curb Weight (as configured) ..... 7,175 lbs

**TOTAL** ..... **9,425 lbs**

Payload ..... 3,184 lbs

Useable Payload ..... 934 lbs

Maximum payload capabilities are for properly equipped vehicles with required equipment and vary based on vehicle configuration, accessories, and option content.

# FREEDMAN

# SEATING CAREGIVER

## **SAFETY FOR ALL PASSENGERS**

Standard 3PT seat belts with optional ICS (Integrated Child Seat) and/or CRS (Child Restraint System) for children



ICS Integrated Child Seat  
FMVSS compliant

Not Just Seats



THE FEATHER WEIGHT SERIES BY

**FREEDMAN**  
SEATING COMPANY

Seating Solutions™



# FREEDMAN



3PT seat belts

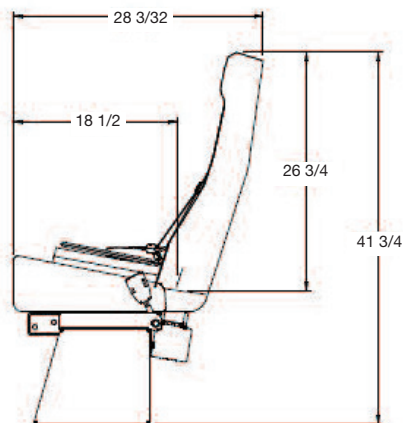
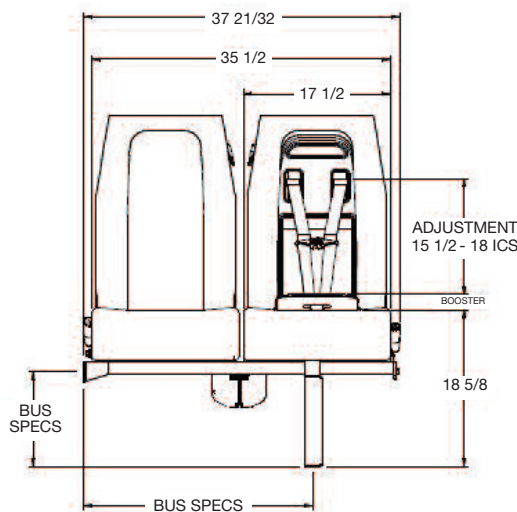

# SEATING CAREGIVER

**Safety for all passengers. Standard 3PT seat belts with optional ICS (Integrated Child Seat) and/or CRS(Child Restraint System) for children.**

The newly upgraded Caregiver seat is designed for a comfortable, safe ride for both children and guardians. 3PT seat belts have been added for adults, while the optional ICS is available for children from 22-78 lbs. A tapered back provides unrestricted viewing for drivers, and best of all, the shoulder belts can be adjusted in seconds without taking the seat apart, avoiding clumsy operations.

#### Standard Features:

- Accommodates children 22–78 lbs
- Standard 3-point seat belts with FMVSS 207 and 210 seat belt anchorage compliance
- Fits where most 3PT seats were placed
- Use existing GO, GO-ES, or 3PT legs

#### Options:

- Available in a wide variety of vinyls and cloths
- Upholstered or US Arms
- Adjustable footrests
- Available as a single or double
- Optional Integrated Child Seat (ICS) accommodates children 22-78 lbs with FMVSS 213 Compliance
  - Fold down tongue can be folded to act as a booster seat
  - Easily adjustable ICS shoulder straps
- Optional Child Restraint System (CRS) with FMVSS 225 Compliance

Not Just Seats



Seating Solutions™

THE FEATHER WEIGHT SERIES BY  
**FREEDMAN**  
SEATING COMPANY

4545 W. Augusta Blvd., Chicago, IL 60651  
(773)524-2440 (800)443-4540 Fax (773)252-7450  
WWW.FREEDMANSEATING.COM  
e-mail: info@freedmanseating.com



Freedman Seating is committed to lessening our impact on the planet. For your convenience, materials are now available online to download at [www.freedmanseating.com](http://www.freedmanseating.com).

We are constantly updating and improving our seats; therefore we reserve the right to change or modify specifications or materials without notice. All Freedman Seating Company seats meet or exceed FMVSS standards.

281.2

282.3

283.2

Test Report Number <b>QS2016-006</b>	<b>AMF Bruns</b> <b>Final Test Report</b>	<u>Test Facility:</u> AMF Bruns Test Centre Hauptstrasse 101 D-26689 Apen Germany
<u>Test Date:</u> 08-12-2016	Testprocedure: <b>ADA FMVSS 49.38 + FMVSS 210</b>	
<p style="text-align: center;"><b>Description of Item Tested</b></p> <p>All Test items are obtained according to AMF Bruns procedure unless LAI-011 noted. All items are tested for compliance with applicable standards, previously reviewed and approved by the party requesting this test, unless otherwise specifically noted:</p> <p style="text-align: center;">AMF-Brunns of America installed Wheelchair securement tie down in rear position</p> <p style="text-align: center;">The Wheelchair restraints system was installed with Q'Straint L Track Fitting on the Smartfloor, The Smartfloor is glued with Sikaflex 265 / Sikaflex 265 DG3 / Sikaflex 552 AT or Sikaflex 255 FC in a Ford Transit Body.</p> <p style="text-align: center;">A ISO 10542 Wheelchair was used to simulate a wheelchair.</p>		
<p style="text-align: center;"><b>Description of Results</b></p> <div style="text-align: center;">  </div>		
<p><b>Summary of FMVSS Title 49, Part 38 )8) (d) ADA (Americans with Disability Act)</b></p> <p>Securement systems on vehicles and their attachments to such vehicles, shall restrain a force in the forward directions of up to 2,500 lb (11,120 N) per securement leg or clamping mechanism and a minimum of 5,000 Pounds for each mobility aid. In addition FMVSS 210 loads were applied.</p>		
<p><b>Summary of FMVSS section 571.210</b></p> <p>A force of 3,000 lb (13,344N) shall be applied to the lap belt at <math>10^\circ \pm 5^\circ</math> above the horizontal plane. The required forces must be reached within 30 seconds from the onset of the test then, when reached must be held for 10 seconds.</p> <p><b>Note: Full compliance with FMVSS and its Regulations, as set forth under 49 USC 301, et. Seq., can only be achieved through proper in- vehicle testing. AMF Bruns GmbH, its agents, employees, affiliates and subsidiaries ("AMF Bruns of America L.P.") is not liable for damages resulting from the installation of any seat in a vehicle that has not been FMVSS tested of any installation of a seat that deviates from a FMVSS tested installation method. AMF Bruns of America L.P. has no responsibility for the design of any vehicle in which the subject seat may be placed, or any resulting damages. The results documented in this report relate only to the items tested, as described herein.</b></p>		
<p style="text-align: center;"><b>Test Opinions and Interpretations</b></p> <p>Note: This Test report is provided solely for the use of the party requesting the same identified below, and for no other person, entity or purpose. Reproduction of this document is strictly prohibited without the prior written permission of AMF Bruns in each instance.</p>		
<p>The Wheelchair system as tested in this chassis with the requirements of FMVSS 49.38 &amp; FMVSS 210</p>		
<u>Test report Reviewed by:</u>	<u>Test Requested By:</u> AMF Bruns of America L.P., 1797 Georgetown Road Hudson, OH 44236	



281.2 282.3 283.2

<b>Test Report Approved By:</b> TÜV NORD Mobilität GmbH & Co. KG F. Heerwagen	
---	--

Test Report Number <b>QS2016-006</b>	<b>AMF Bruns</b> <b>Final Test Report</b>	<b>Test Facility:</b> AMF Bruns Test Centre Hauptstrasse 101 D-26689 Apen Germany
<b>Test Date:</b> 08-12-2016	Testprocedure: ADA FMVSS 49.38 + FMVSS 210	

**Requirements for compliant test**

**Yes/No /N/A**

Test artifact reached CMVSS/FMVSS loads within 30 seconds	Yes
Test artifact sustained CMVSS/FMVSS loads for 10 seconds or more	Yes
Seat frame released from it's adjusted position?	n/a
Seat frame or seat adjusters detach from the test platform/vehicle?	Yes
Seat frame detaches from seat adjuster mechanism?	n/a
Seat adjuster separates?	n/a
Calibration Papers Available	Yes

**Test Results**

The test article was able to achieve and maintain the minimum required loads. All seat anchorages appeared to be intact after the test.

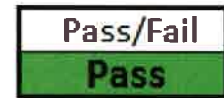

**Summary:**

<b>Chassis:</b>	<i>Ford Transit</i>
<b>Floor Anchorage:</b>	<i>Smartfloor / Q'Straint L Track Fitting</i>
<b>Shoulder Anchorage:</b>	<i>Pocket / Q'Straint L Track Fitting</i>

281.2

282.3

283.2

<b>Test Report Number</b> <b>QS2016-003</b>	<b>AMF Bruns</b> <b>Final Test Report</b>	<b>Test Facility:</b> AMF Bruns Test Centre Hauptstrasse 101 D-26689 Apen Germany
<b>Test Date:</b> 20-04-2016	<b>Testprocedure:</b> <b>FMVSS/CMVSS 207/210</b>	

**Description of Item Tested**

AMF-Bruns of America installed 4 Smartseat Easy seats with 290 mm height Fixedlegs / Smartlegs on a Smartfloor.

The Smartfloor is glued with Sikaflex 265 / Sikaflex 265 DG3 / Sikaflex 552 or Sika 255 FC in a Ford Transit Body.

**Description of Results**

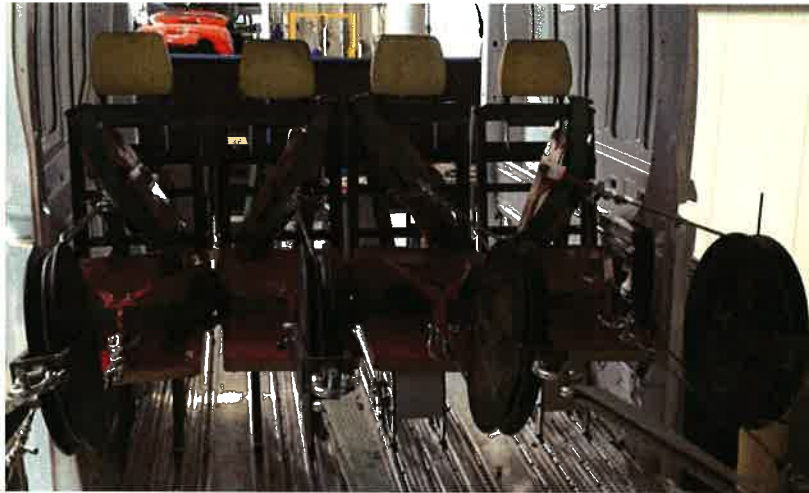

**Summary of FMVSS 571.207.S4.2a & Section 571.210.S5.1**

A force of 3,000 lb (13,344N) shall be applied to each lap belt, and shoulder at 10° ± 5° above the horizontal plane. In addition, a force of 1,100 lbs ( 4,893N) equal to 20 times the system mass was applied simultaneously through the CG of the seating system. The required forces must be reached within 30 seconds from onset of the test then, when reached must be held for 10 seconds. The total forces applied during this test was 7,100 lb (31,582N)

Note: Full compliance with FMVSS and its Regulations, as set forth under 49 USC 301, et. Seq., can only be achieved through proper in- vehicle testing. AMF Bruns GmbH, its agents, employees, affiliates and subsidiaries (" AMF Bruns of America L.P.) is not liable for damages resulting from the installation of any seat in a vehicle that has not been FMVSS tested of any installation of a seat that deviates from a FMVSS tested installation method. AMF Bruns of America L.P. has no responsibility for the design of any vehicle in which the subject seat may be placed, or any resulting damages. The results documented in this report relate only to the items tested, as described herein.

**Test Opinions and Interpretations**

Note: This Test report is provided solely for the use of the party requesting the same identified below, and for no other person, entity or purpose. Reproduction of this document is strictly prohibited without the prior written permission of AMF Bruns in each instance.

The seat as tested met the dime and load requirements of FMVSS/CMVSS 207/210

<b>Test report Reviewed by:</b>	<b>Test Requested By:</b> AMF Bruns of America LP, 1797 Georgetown Road Hudson, OH 44236
<b>Test Report Approved By:</b> TÜV NORD Mobilität GmbH & Co. KG F. Heerwagen	

281.2      282.3      283.2

Test Report Number <b>QS2016-003</b>	<b>AMF Bruns</b> <b>Final Test Report</b>	<b>Test Facility:</b> AMF Bruns Test Centre Hauptstrasse 101 D-26689 Apen Germany
<b>Test Date:</b> 20-04-2016	Testprocedure: FMVSS/CMVSS 207/210	

**Requirements for compliant test**

**Yes/No /N/A**

Test artifact reached CMVSS/FMVSS loads within 30 seconds	Yes
Test artifact sustained CMVSS/FMVSS loads for 10 seconds or more	Yes
Seat frame released from it's adjusted position?	n/a
Seat frame or seat adjusters detach from the test platform/vehicle?	Yes
Seat frame detaches from seat adjuster mechanism?	n/a
Seat adjuster separates?	n/a
Calibration Papers Available	Yes

**Test Results**

The test article was able to achieve and maintain the minimum required loads. All seat anchorages appeared to be intact after the test.

Pass/Fail
<b>Pass</b>

**Summary:**

**Chassis:**                      *Ford Transit*  
**Seat:**                              *Smartseat Easy (reclining)*  
**Seatleg:**                          *Fixedleg / Smartleg*

Federal Certifications

CERTIFICATION AND RESTRICTIONS ON LOBBYING

I, Coy Lightfoot, Commercial Manager hereby certify  
(Name and title of official)

On behalf of Superior Van & Mobility, LLC. that:  
(Name of Bidder/Company Name)

- No federal appropriated funds have been paid or will be paid, by or on behalf of the undersigned, to any person for influencing or attempting to influence an officer or employee of any agency, a Member of Congress, and officer or employee of Congress, or an employee of a Member of Congress in connection with the awarding of any federal contract, the making of any federal grant, the making of any federal loan, the entering into of any cooperative agreement, and the extension, continuation, renewal, amendment, or modification of any federal contract, grant, loan, or cooperative agreement.
- If any funds other than federal appropriated funds have been paid or will be paid to any person influencing or attempting to influence an officer or employee of any agency, a Member of Congress, and officer or employee of Congress, or an employee of a Member of Congress in connection with the federal contract, grant, loan, or cooperative agreement, the undersigned shall complete and submit Standard Form – LLL, "Disclosure Form to Report Lobbying," in accordance with its instructions.
- The undersigned shall require that the language of this certification be included in the award documents for all sub-awards at all tiers (including sub-contracts, sub-grants and contracts under grants, loans, and cooperative agreements) and that all sub-recipients shall certify and disclose accordingly.

This certification is a material representation of fact upon which reliance was placed when this transaction was made or entered into. Submission of this certification is a prerequisite for making or entering into this transaction imposed by 31 U.S.C. § 1352 (as amended by the Lobbying Disclosure Act of 1995). Any person who fails to file the required certification shall be subject to a civil penalty of not less than \$10,000 and not more than \$100,000 for each such failure.

The undersigned certifies or affirms the truthfulness and accuracy of the contents of the statements submitted on or with this certification and understands that the provisions of 31 U.S.C. Section 3801, et seq., are applicable thereto.

Name of Bidder/Company Name: Superior Van & Mobility, LLC.

Type or print name: Coy Lightfoot

Signature of authorized representative: Coy Lightfoot Date 01 / 05 / 2023

Signature of notary and SEAL: Cheryl L. Olmstead



**GOVERNMENT-WIDE DEBARMENT AND SUSPENSION  
(NONPROCUREMENT)**

**Instructions for Certification:** By signing and submitting this bid or proposal, the prospective lower tier participant is providing the signed certification set out below.

(1) It will comply and facilitate compliance with U.S. DOT regulations, "Nonprocurement Suspension and Debarment," 2 CFR part 1200, which adopts and supplements the U.S. Office of Management and Budget (U.S. OMB) "Guidelines to Agencies on Governmentwide Debarment and Suspension (Nonprocurement)," 2 CFR part 180,

(2) To the best of its knowledge and belief, that its Principals and Subrecipients at the first tier:

a. Are eligible to participate in covered transactions of any Federal department or agency and are not presently:

1. Debarred,
2. Suspended,
3. Proposed for debarment,
4. Declared ineligible,
5. Voluntarily excluded, or
6. Disqualified,

b. Its management has not within a three-year period preceding its latest application or proposal been convicted of or had a civil judgment rendered against any of them for:

1. Commission of fraud or a criminal offense in connection with obtaining, attempting to obtain, or performing a public (Federal, State, or local) transaction, or contract under a public transaction,
2. Violation of any Federal or State antitrust statute, or,
3. Commission of embezzlement, theft, forgery, bribery, falsification or destruction of records, making any false statement, or receiving stolen property,

c. It is not presently indicted for, or otherwise criminally or civilly charged by a governmental entity (Federal, State, or local) with commission of any of the offenses listed in the preceding subsection 2.b of this Certification,

d. It has not had one or more public transactions (Federal, State, or local) terminated for cause or default within a three-year period preceding this Certification,

e. If, at a later time, it receives any information that contradicts the statements of subsections 2.a – 2.d above, it will promptly provide that information to FTA,

f. It will treat each lower tier contract or lower tier subcontract under its Project as a covered lower tier contract for purposes of 2 CFR part 1200 and 2 CFR part 180 if it:

1. Equals or exceeds \$25,000.,
2. Is for audit services, or,
3. Requires the consent of a Federal official, and

g. It will require that each covered lower tier contractor and subcontractor:

1. Comply and facilitate compliance with the Federal requirements of 2 CFR parts 180 and 1200, and
2. Assure that each lower tier participant in its Project is not presently declared by any Federal department or agency to be:

- a. Debarred from participation in its federally funded Project,
- b. Suspended from participation in its federally funded Project,
- c. Proposed for debarment from participation in its federally funded Project,
- d. Declared ineligible to participate in its federally funded Project,
- e. Voluntarily excluded from participation in its federally funded Project, or
- f. Disqualified from participation in its federally funded Project, and

3. It will provide a written explanation as indicated on a page attached in FTA's TrAMS platform or the Signature Page if it or any of its principals, including any of its first tier Subrecipients or its Third-Party Participants at a lower tier, is unable to certify compliance with the preceding statements in this Certification Group.

(3) It will provide a written explanation as indicated on a page attached in FTA's TrAMS platform or the Signature Page if it or any of its principals, including any of its first tier Subrecipients or its Third-Party Participants at a lower tier, is unable to certify compliance with the preceding statements in this Certification Group.

**Certification**

Contractor: Superior Van & Mobility, LLC.

Signature of Authorized Official: Cay Lightfoot Date 01/05/2023

Name and Title of Contractor's Authorized Official: Cay Lightfoot, Commercial MGR

## BUS TESTING CERTIFICATION

The undersigned bidder [Contractor/Manufacturer] certifies that the vehicle model or vehicle models offered in this bid submission complies with 49 CFR Part 665.

A copy of the test report (for each bid ITEM) prepared by the Federal Transit Administration's (FTA) Altoona, Pennsylvania Bus Testing Center is attached to this certification and is a true and correct copy of the test report as prepared by the facility.

The undersigned understands that misrepresenting the testing status of a vehicle acquired with Federal financial assistance may subject the undersigned to civil penalties as outlined in the U.S. Department of Transportation's regulation on Program Fraud Civil Remedies, 49 CFR Part 31. In addition, the undersigned understands that FTA may suspend or debar a manufacturer under the procedures in 49 CFR Part 29.

Name of Bidder/Company Name: Superior Van & Mobility, LLC.

Type or print name: Coy Lightfoot

Signature of authorized representative: Coy Lightfoot

Signature of notary and SEAL: C Cheryl L Olmstead

Date of Signature: 01/05/2023





**PRE- AWARD CERTIFICATION REQUIREMENT FOR PROCUREMENT OF ROLLING STOCK (RECIPIENT)**

**BUY AMERICA REQUIREMENTS:** Contractor shall complete and submit a declaration certifying either compliance or noncompliance with Buy America. If contractor certifies compliance with Buy America, it shall submit documentation listing:

- A. Component and subcomponent parts of the rolling stock to be purchased identified by manufacturer of the parts, their country of origin and costs; and
- B. The location of the final assembly point for the rolling stock, including a description of the activities that will take place at the final assembly point and the cost of final assembly.
- C. Solicitation Specification Requirements: Contractor shall submit evidence that it will be capable of meeting the bid specifications.
- D. Federal Motor Vehicle Safety Standards (FMVSS): Contractor shall submit 1) manufacturer's FMVSS self-certification sticker information that the vehicle complies with relevant FMVSS or 2) manufacturer's certified statement that the buses will not be subject to FMVSS regulations.

As required by Title 49 of the CFR, Part 663 – Subpart B, \_\_\_\_\_ (the recipient) is satisfied that the buses to be purchased, \_\_\_\_\_ (number and description of buses) from Driverge Vehicle Inovations (the manufacturer), meet the requirements of Section 165(b)(3) of the Surface Transportation Assistance Act of 1982, as amended. The recipient or its appointed analyst \_\_\_\_\_ the analyst, not the manufacturer or its agent), has reviewed documentation provided by the manufacturer, which lists (1) the proposed component and subcomponent parts of the buses identified by manufacturer, country of origin, and cost; and (2) the proposed location of the final assembly point for the buses, including a description of the activities that will take place at the final assembly point and the cost of final assembly.

**PRE-AWARD PURCHASER'S REQUIREMENTS CERTIFICATION**

As required by Title 49 of the CFR, Part 663 – Subpart B, \_\_\_\_\_ (the recipient) certifies that the buses to be purchased, \_\_\_\_\_ (number and description of buses) from Driverge Vehicle Inovations (the manufacturer), are the same product described in the recipient's solicitation specification and that the proposed manufacturer is a responsible manufacturer with the capability to produce a bus that meets the specifications.

**PRE-AWARD FMVSS COMPLIANCE CERTIFICATION**

As required by Title 49 of the CFR, Part 663 – Subpart D, \_\_\_\_\_ (the recipient) certifies that it received, at the pre-award stage, a copy of Driverge Vehicle Inovations's (the manufacturer) self-certification information stating that the buses, \_\_\_\_\_ (number and description of buses), will comply with the relevant Federal Motor Vehicle Safety Standards issued by the National Highway Traffic Safety Administration in Title 49 of the Code of Federal Regulations, Part 571.

Date : 1/18/2023

Signature : 

Title : Commercial Mgr.

## PRE-AWARD CERTIFICATION FOR PROCUREMENT OF ROLLING STOCK (VENDOR)

**PRE-AWARD AUDIT REQUIREMENTS:** A recipient purchasing revenue service rolling stock with FTA funds must ensure that a pre-award audit under this part is complete before the recipient enters into a formal contract for the purchase of such rolling stock.

**DESCRIPTION OF PRE-AWARD AUDIT:** A pre-award audit under this part includes— (a) A Buy America certification; (b) A purchaser's requirements certification; and (c) Where appropriate, a manufacturer's Federal Motor Vehicle Safety certification information.

**PRE-AWARD BUY AMERICA CERTIFICATION:** For purposes of this part, a pre-award Buy America certification is a certification that the recipient keeps on file that:

- a. There is a letter from FTA which grants a waiver to the rolling stock to be purchased from the Buy America requirements under section 165(b)(1), (b)(2), or (b)(4) of the Surface Transportation Assistance Act of 1982, as amended; or
- b. The recipient is satisfied that the rolling stock to be purchased meets the requirements of section 165(a) or (b)(3) of the Surface Transportation Assistance Act of 1982, as amended, after having reviewed itself or through an audit prepared by someone other than the manufacturer or its agent documentation provided by the manufacturer which lists:
  1. The Component and subcomponent parts of the rolling stock that are produced in the United States is more than sixty percent (60%) of the cost of all components and subcomponents of the vehicle identified by the manufacturer; and
  2. The location of the final assembly must take place in the United States (49 CFR 661.11), including a description of the activities that will take place at the final assembly point and the cost of final assembly.

**PRE-AWARD PURCHASERS REQUIREMENTS CERTIFICATION:** For purposes of this part, a pre-award purchaser's requirements certification is a certification a recipient keeps on file that:

- a. The rolling stock the recipient is contracting for is the same product described in the purchaser's solicitation specification; and
- b. The proposed manufacturer is a responsible manufacturer with the capability to produce a vehicle that meets the recipient's specification set forth in the recipient's solicitation.

If buses or other rolling stock (including train control, communication, and traction power equipment) are being procured, the appropriate certificate as set forth below shall be completed and submitted by each bidder in accordance with the requirements in 49 CFR 661.13(b).

**PRE-AWARD FMVSS COMPLIANCE CERTIFICATION:** As required by Title 49 of the CFR, Part 663 – Subpart D, the recipient certifies that it received, at the pre-award stage, a copy of the manufacturers self-certification information stating that the buses will comply with the relevant Federal Motor Vehicle Safety Standards issued by the National Highway Traffic Safety Administration in Title 49 of the Code of Federal Regulations, Part 571.

### **Bidder or Offeror Certificate of COMPLIANCE with Buy America and FMVSS Rolling Stock Requirements**

As required by 49 CFR Part 663, the bidder or offeror hereby certifies that it will comply with the requirements of 49 U.S.C. 5323(j), and the applicable regulations of 49 CFR 661.11.

Company Superior Van + Mobility LLC  
Name Cory Lightfoot Title Commercial Manager  
Signature [Signature] Date 01/05/2023

### **Bidder or Offeror Certificate of NON-COMPLIANCE with Buy America and FMVSS Rolling Stock Requirements**

As required by 49 CFR Part 663, the bidder or offeror hereby certifies that it cannot comply with the requirements of 49 U.S.C. 5323(j), but may qualify for an exception to the requirement consistent with 49 U.S.C. 5323(j)(2), as amended, and the applicable regulations in 49 CFR 661.7.

Company \_\_\_\_\_  
Name \_\_\_\_\_ Title \_\_\_\_\_  
Signature \_\_\_\_\_ Date \_\_\_\_/\_\_\_\_/\_\_\_\_

**ON-SITE MANUFACTURER INSPECTION COMPLIANCE CERTIFICATION**

(Post-Delivery purchaser's requirement, in compliance with the federal requirements of 49 U.S.C. Section 5323(m))

**ON-SITE MANUFACTURER INSPECTION COMPLIANCE CERTIFICATION**

(Rolling Stock Procurements for more than 10 vehicles for areas >200,000 in population)

As required by 49 CFR Part 663-Subpart C, the

\_\_\_\_\_  
(Recipient's name)  
Certifies that a resident inspector,

\_\_\_\_\_  
(Name of inspector)

Was at Driverge Vehicle Inovations  
(the manufacturer's)

manufacturing site during the period of manufacture of the buses,  
\_\_\_\_\_  
(description of buses).

The inspector visually inspecting the buses, the \_\_\_\_\_ (the recipient) has reviewed the inspection documentation, maintains a copy of this report, and certifies that the buses meet the contract specifications.

**ON-SITE MANUFACTURER INSPECTION COMPLIANCE CERTIFICATION**

(Rolling Stock Procurements for more than 20 vehicles for areas < 200,000 in population)

As required by 49 CFR Part 663-Subpart C, the

\_\_\_\_\_  
(Recipient's name)

Certifies that a resident inspector,

\_\_\_\_\_  
(Name of inspector)

Was at Driverge Vehicle Inovations  
(the manufacturer's)

manufacturing site during the period of manufacture of the buses,  
\_\_\_\_\_  
(description of buses).

The inspector visually inspecting the buses, the \_\_\_\_\_ (the recipient) has reviewed the inspection documentation, maintains a copy of this report, and certifies that the buses meet the contract specifications.

Signature \_\_\_\_\_ Date \_\_\_\_/\_\_\_\_/\_\_\_\_

Title \_\_\_\_\_

## TRANSIT VEHICLE MANUFACTURER (TVM) CERTIFICATION

Pursuant to the provisions of Section 105(f) of the Surface Transportation Assistance Act of 1982, each bidder for this contract must certify that it has complied with the requirements of 49 CFR Part 26.49, regarding the participation of Disadvantaged Business Enterprises (DBE) in FTA assisted procurements of transit vehicles. Absent this certification, properly completed and signed, a bid shall be deemed non-responsive.

### Certification:

I hereby certify, for the bidder named below, that it has complied with the provisions of 49 CFR Part 26.49 and that I am duly authorized by said bidder to make this certification.

### BIDDER/COMPANY

Name of Bidder/Company Superior Van & Mobility, LLC.  
Signature of Representative Coy Lightfoot  
Type or Print Name Coy Lightfoot  
Title Commercial Manager Date 01, 05, 2023

### NOTARY

Type or Print Name Cheryl L Olmstead  
Signature of Notary Cheryl L Olmstead  
Place Notary SEAL Here:



## POST DELIVERY CERTIFICATION FOR PROCUREMENT OF ROLLING STOCK (RECIPIENT)

**POST DELIVERY AUDIT REQUIREMENTS:** A recipient purchasing revenue service rolling stock with FTA funds must ensure that a post-delivery audit is complete before title to the rolling stock is transferred to the recipient.

**DESCRIPTION OF POST DELIVERY AUDIT:** A post-delivery audit under this part includes: (a) A post-delivery Buy America certification as described in 49 CFR 663.35; (b) A post-delivery purchaser's requirements certification as described in 49 CFR 663.37; and (c) When appropriate, a manufacturer's Federal Motor Vehicle Safety Standard self-certification information as described in 49 CFR 663.41 or 49 CFR 663.43.

**POST DELIVERY BUY AMERICA CERTIFICATION:** For purposes of this part, a post-delivery Buy America certification is a certification that the recipient keeps on file that:

- a. There is a letter from FTA which grants a waiver to the rolling stock received from the Buy America requirements under sections 165 (b)(1), or (b)(4) of the Surface Transportation Assistance Act of 1982, as amended; or
- b. The recipient is satisfied that the rolling stock received meets the requirements of section 165 (a) or (b)(3) of the Surface Transportation Assistance Act of 1982, as amended, after having reviewed itself or by means of an audit prepared by someone other than the manufacturer or its agent documentation provided by the manufacturer which lists:
  1. Components and subcomponent parts of the rolling stock identified by manufacturer of the parts, their country of origin and costs; and
  2. The actual location of the final assembly point for the rolling stock including a description of the activities which took place at the final assembly point and the cost of the final assembly.

### POST DELIVERY PURCHASERS REQUIREMENTS CERTIFICATION

For purposes of this part, a post-delivery purchaser's requirements certification is a certification that the recipient keeps on file that—

- a. Except for procurements covered under paragraph (c) in this section, a resident inspector (other than an agent or employee of the manufacturer) was at the manufacturing site throughout the period of manufacture of the rolling stock to be purchased and monitored and completed a report on the manufacture of such rolling stock. Such a report, at a minimum, shall:
  1. Provide accurate records of all vehicle construction activities; and
  2. Address how the construction and operation the vehicles fulfills the contract specifications.
- b. After reviewing the report required under paragraph (a) of this section, and visually inspecting and road testing the delivered vehicles, the vehicles meet the contract specifications.
- c. For procurements of:
  1. Ten or fewer buses; or
  2. Procurements of twenty vehicles or fewer serving rural (other than urbanized) areas, or urbanized areas of 200,000 people or fewer; or
  3. Any number of primary manufacturer standard production and unmodified vans, after visually inspecting and road testing the vehicles, the vehicles meet the contract specifications.

### POST DELIVERY AUDIT REVIEW

- a. If a recipient cannot complete a post-delivery audit because the recipient or its agent cannot certify Buy America compliance or that the rolling stock meets the purchaser's requirements specified in the contract, the rolling stock may be rejected and final acceptance by the recipient will not be required. The recipient may exercise any legal rights it has under the contract or at law.
- b. This provision does not preclude the recipient and manufacturer from agreeing to a conditional acceptance of rolling stock pending manufacturer's correction of deviations within a reasonable period of time.

### POST DELIVERY FMVSS COMPLIANCE CERTIFICATION

If a vehicle purchased under this part is subject to the Federal Motor Vehicle Safety Standards issued by the National Highway Traffic Safety Administration in part 571 of this title, a recipient shall keep on file its certification that it received, both at the pre-award and post-delivery stage, a copy of the manufacturer's self-certification information that the vehicle complies with relevant Federal Motor Vehicle Safety Standards.

#### Certificate of COMPLIANCE with Buy America and FMVSS Rolling Stock Requirements

The recipient hereby certifies that it has reviewed and ensures the bidder or offeror has complied with the requirements of 49 U.S.C. 5323(j), and the applicable regulations of 49 CFR 661.11.

Company Superior Van & Mobility, LLC.

Name Coy Lightfoot

Title Commercial Mgr.

Signature Coy Lightfoot

Date 1/18/2023

#### Certificate of NON-COMPLIANCE, Buy America and FMVSS Rolling Stock Requirements.

The recipient hereby certifies that it has reviewed and determined the bidder or offeror cannot comply with the requirements of 49 U.S.C. 5323(j), but may qualify for an exception to the requirement consistent with 49 U.S.C. 5323(j)(2)(C), and the applicable regulations in 49 CFR 661.7.

Company \_\_\_\_\_

Name \_\_\_\_\_

Title \_\_\_\_\_

Signature \_\_\_\_\_

Date \_\_\_\_\_

## POST DELIVERY CERTIFICATION FOR PROCUREMENT OF ROLLING STOCK (VENDOR)

**POST DELIVERY AUDIT REQUIREMENTS:** A recipient purchasing revenue service rolling stock with FTA funds must ensure that a post-delivery audit is complete before title to the rolling stock is transferred to the recipient.

**DESCRIPTION OF POST DELIVERY AUDIT:** A post-delivery audit under this part includes: (a) A post-delivery Buy America certification as described in 49 CFR 663.35; (b) A post-delivery purchaser's requirements certification as described in 49 CFR 663.37; and (c) When appropriate, a manufacturer's Federal Motor Vehicle Safety Standard self-certification information as described in 49 CFR 663.41 or 49 CFR 663.43.

### POST DELIVERY BUY AMERICA CERTIFICATION

For purposes of this part, a post-delivery Buy America certification is a certification that the recipient keeps on file that:

- a. There is a letter from FTA which grants a waiver to the rolling stock received from the Buy America requirements under sections 165 (b)(1), or (b)(4) of the Surface Transportation Assistance Act of 1982, as amended; or
- b. The recipient is satisfied that the rolling stock received meets the requirements of section 165 (a) or (b)(3) of the Surface Transportation Assistance Act of 1982, as amended, after having reviewed itself or by means of an audit prepared by someone other than the manufacturer or its agent documentation provided by the manufacturer which lists:
  1. Components and subcomponent parts of the rolling stock identified by manufacturer of the parts, their country of origin and costs; and
  2. The actual location of the final assembly point for the rolling stock including a description of the activities which took place at the final assembly point and the cost of the final assembly.

### POST DELIVERY PURCHASERS REQUIREMENTS CERTIFICATION

For purposes of this part, a post-delivery purchaser's requirements certification is a certification that the recipient keeps on file that

- a. Except for procurements covered under paragraph (c) in this section, a resident inspector (other than an agent or employee of the manufacturer) was at the manufacturing site throughout the period of manufacture of the rolling stock to be purchased and monitored and completed a report on the manufacture of such rolling stock. Such a report, at a minimum, shall:
  1. Provide accurate records of all vehicle construction activities; and
  2. Address how the construction and operation of the vehicles fulfills the contract specifications.
- b. After reviewing the report required under paragraph (a) of this section, and visually inspecting and road testing the delivered vehicles, the vehicles meet the contract specifications.
- c. For procurements of:
  1. Ten or fewer buses; or
  2. Procurements of twenty vehicles or fewer serving rural (other than urbanized) areas, or urbanized areas of 200,000 people or fewer; or
  3. Any number of primary manufacturer standard production and unmodified vans, after visually inspecting and road testing the vehicles, the vehicles meet the contract specifications.

### POST DELIVERY AUDIT REVIEW

- a. If a recipient cannot complete a post-delivery audit because the recipient or its agent cannot certify Buy America compliance or that the rolling stock meets the purchaser's requirements specified in the contract, the rolling stock may be rejected and final acceptance by the recipient will not be required. The recipient may exercise any legal rights it has under the contract or at law.
- b. This provision does not preclude the recipient and manufacturer from agreeing to a conditional acceptance of rolling stock pending manufacturer's correction of deviations within a reasonable period of time.

### POST DELIVERY FMVSS COMPLIANCE CERTIFICATION

If a vehicle purchased under this part is subject to the Federal Motor Vehicle Safety Standards issued by the National Highway Traffic Safety Administration in part 571 of this title, a recipient shall keep on file its certification that it received, both at the pre-award and post-delivery stage, a copy of the manufacturer's self-certification information that the vehicle complies with relevant Federal Motor Vehicle Safety Standards.

#### Certificate of COMPLIANCE with Buy America and FMVSS Rolling Stock Requirements

The recipient hereby certifies that it has reviewed and ensures the bidder or offeror has complied with the requirements of 49 U.S.C. 5323(j), and the applicable regulations of 49 CFR 661.11.

Agency Superior Van + Mobility, LLC.  
Name Col Lightfoot Title Commercial Manager  
Signature Col Lightfoot Date 01/05/2023

#### Certificate of NON-COMPLIANCE, Buy America and FMVSS Rolling Stock Requirements.

The recipient hereby certifies that it has reviewed and determined the bidder or offeror cannot comply with the requirements of 49 U.S.C. 5323(j), but may qualify for an exception to the requirement consistent with 49 U.S.C. 5323(j)(2)(C), and the applicable regulations in 49 CFR 661.7.

Agency \_\_\_\_\_  
Name \_\_\_\_\_ Title \_\_\_\_\_  
Signature \_\_\_\_\_ Date \_\_\_\_\_